

# Loading Guidelines

Code of practice for the loading and securing  
of goods on railway wagons

Volume 1

Principles

Version 01/04/2020

4<sup>st</sup> edition



INTERNATIONAL UNION  
OF RAILWAYS

<b>Release history</b>	
<b>Version</b>	<b>Changes/Numbers</b>
01/04/2017	Complete revision
01/04/2018	1.1, 1.3, 1.4, 5.4.1, 5.9.1, 7, 8, 8.2, 8.3, 8.10, 8.11, 8.18, 10, 11.2.4
01/04/2019	1.2, 3.1, 5.3.2, 5.4.4, 5.5.4, 12, 13
01/04/2020	1.1, 1.4, 2.1, 5.3.2, 5.4.1, 6, 8.1, 8.2, 8.3, 8.7, 9.5, 10, 11.4

## Contents

- 1 Introductory provisions
  - 1.1 Scope of validity
  - 1.2 Structure
  - 1.3 Stresses arising during transit
  - 1.4 Goods forming the load
  - 1.5 Formation of load units
  - 1.6 Friction
- 2 Use of wagons, transport units, and intermodal loading units (ILUs)
  - 2.1 General indications
  - 2.2 Floor
  - 2.3 Walls, sides and doors
  - 2.4 Sheeting devices
  - 2.5 Stanchions
  - 2.6 Securing devices (rings, hooks, eyelets)
  - 2.7 Built-in load securing equipment
- 3 Wagon loads
  - 3.1 Line categories
  - 3.2 Load limits
  - 3.3 Distribution of the load
  - 3.4 Concentrated loads
  - 3.5 Verification of load distribution
- 4 Permissible dimensions of the load
  - 4.1 Loading gauges and restrictions
  - 4.2 Protrusion of the wagon headstock
  - 4.3 Buffer wagons
  - 4.4 Permanently-coupled, multiple and articulated wagons
- 5 Methods of loading and securing
  - 5.1 Basic principles
  - 5.2 Goods loaded in bulk
  - 5.3 Powdery goods
  - 5.4 Goods loaded in compact or rigid formation
  - 5.5 Loading with possibility of sliding lengthways in the wagon
  - 5.6 Goods liable to rolling
  - 5.7 Goods liable to tipping
  - 5.8 Goods in stacks
  - 5.9 Goods loaded on several wagons
- 6 Covering of loads
  - 6.1 Covering with sheets/single-use sheets
  - 6.2 Covering using mesh or netting
- 7 Exceptional consignments
- 8 Table 1: List of the loading gauges
  - 8.1 Table 1<sub>1</sub>: International loading gauge
  - 8.2 Table 1<sub>2</sub>: Loading gauge (UIC) GA
  - 8.3 Table 1<sub>3</sub>: Loading gauge (UIC) GB
  - 8.4 Table 1<sub>4</sub>: Loading gauge accepted by LG, HSH, GySEV, ZRS, ZFBH, PKP, BDZ, CFR, CD, MAV, ZSSK (ZSR), MZ, AAE, JZ, CH, TCDD, HZ, SZ, DB, ÖBB, CFL, NS, DSB, CFS, IRR
  - 8.5 Table 1<sub>5</sub>: Loading gauge accepted by VR
  - 8.6 Table 1<sub>6</sub>: Loading gauge accepted by BLS, SBB
  - 8.7 Table 1<sub>7</sub>: Loading gauge accepted by FNME, FS
  - 8.8 Table 1<sub>8</sub>: Loading gauge accepted in Great Britain
  - 8.9 Table 1<sub>9</sub>: Loading gauge accepted by RENFE, CP
  - 8.10 Table 1<sub>10</sub>: Loading gauge accepted by TRAFIKVERKET (Sweden)
  - 8.11 Table 1<sub>11</sub>: reserved
  - 8.12 Table 1<sub>12</sub>: Loading gauge accepted by TCDD
  - 8.13 Table 1<sub>13</sub>: Loading gauge accepted by TCDD
  - 8.14 Table 1<sub>14</sub>: Loading gauge accepted by TCDD
  - 8.15 Table 1<sub>15</sub>: Loading gauge accepted by C (NSB)
  - 8.16 Table 1<sub>16</sub>: Loading gauge accepted by SNCB
  - 8.17 Table 1<sub>17</sub>: Loading gauge accepted by RAI
  - 8.18 Table 1<sub>18</sub>: SNCF
- 9 Table 2: Loading Tables
  - 9.1 Table 2<sub>1</sub>: Restrictions on load width on lines on the Continent
  - 9.2 Table 2<sub>2</sub>: (reserved)
  - 9.3 Table 2<sub>3</sub>: Restrictions on load width on lines on the Continent
  - 9.4 Table 2<sub>4</sub>: (reserved)
  - 9.5 Table 2<sub>5</sub>: Restrictions on load width on lines on the Continent
  - 9.6 Table 2<sub>6</sub>: Restrictions on load width on lines in Finland (VR)
  - 9.7 Table 2<sub>7</sub>: Restrictions on load width on lines in Finland (VR)
- 10 Table 3: Flaps on flat wagons which can be lowered without infringing the international gauge
- 11 Table 4: Impact test for loading methods and loose fastenings
  - 11.1 Purpose
  - 11.2 Test conditions
  - 11.3 Analysis of results
  - 11.4 Dangerous goods (RID)
  - 11.5 Conversion table
- 12 Table 5: Goods transported under special aerodynamic conditions in long tunnels
- 13 Template 1





# 1 Introductory provisions

## 1.1 Scope of validity

These loading guidelines are valid for train speeds up to and including 120 km/h.

Their application is a guarantee for operating safety and prevents damage to goods and wagons. The consigner/shipper shall be responsible for observance of these guidelines. In the event of non-compliance, the Railway Undertakings (RUs) may refuse to take on the consignment.

The loading guidelines describe the loading condition and securing during the shipment procedure.

References to standards in the UIC Loading Guidelines are always to the current version of the standard referred to.

For dangerous goods, the version of the RID (Regulations governing the international carriage of dangerous goods by rail) in force should be adhered to.

	The provisions set out in	
the left-hand column apply to		the right-hand column apply to
- individual wagons and groups of wagons subject to normal shunting conditions.		- wagons not subject to hump and fly shunting in block trains, - wagons used in combined transport trains with containers, swap bodies, semi-trailers and lorries, where appropriate with trailers, - wagons fitted with long-stroke shock absorbers (the letter code for these wagons includes the letter "j").

Text printed across the full width of the page is valid in all cases.

Wagons withdrawn from block trains should be:

- conveyed further under special conditions if necessary, **or**
- undergo additional treatment rendering them suitable for normal shunting.

Provisions marked with a vertical line in the margin denote changes introduced on the date shown at the foot of the page.

## 1.2 Structure

Volumes 1 and 2 are published by UIC in English, French, and German. Railways may have them translated into other national languages as required, but UIC may not be held liable for any issues arising from such translations. In the event of conflicting interpretations, the French version shall be considered authoritative.

### Volume 1 – Principles

Contains the rules to be observed for the loading and securing of goods. These rules are mandatory.

### Volume 2 – Goods

Contains loading guidelines for specific types of goods, developed in compliance with the principles set out in volume 1 on the basis of tests in practice. They may include either more relaxed or stricter requirements for securing loads. Other types of loading and load securing are permitted, providing they meet the provisions of volume 1. This also applies when specially-equipped wagons are used to guarantee operating safety in other ways.

The RUs also publish<sup>1)</sup> colour-coded loading examples covering other types of loading or wagons fitted with special securing devices.

These examples are printed as follows:

- blue= all the conditions of volume 1 are met, example is valid for all RUs; The blue loading example is distributed to the UIC Freight Department and is presented on the UIC website.
- pink= the example includes derogations from volume 1 and is covered by an agreement between certain RUs; The pink loading example is distributed to the relevant RUs and is presented with the number, title and point of contact of the loading example on the UIC website.
- yellow= the example includes derogations from volume 1 and is only valid on trains run by the issuing RU.

<sup>1)</sup> Following the plenary meeting of the UIC Loading Guidelines General Assembly, the amendments to volumes 1 and 2, the blue loading examples and the tabular representation of the pink loading examples entering into force on 1 April of each calendar year are presented on the Loading Guidelines page on the UIC website. Responsibility for the contents of the published documents takes effect thereafter.

For new loading methods, it may be necessary to demonstrate that the load is sufficiently secured:

- lengthways in the wagon by carrying out buffing tests as per table 4,
- crosswise in the wagon by running tests or tests on the dynamic rig.

Operating safety must in any event be guaranteed.

## Line categories

The lines used by RUs are published on the UIC website (LOCA).

### 1.3 Stresses arising during transit

The stresses to be taken into account during rail transit are as follows:

- lengthways in the wagon,
  - up to four times the mass of the load (4 g) for goods that are rigidly secured,
  - up to once the mass of the load (1 g) for goods that can slide lengthways in the wagon,
- crosswise in the wagon up to 0.5 times the mass of the load (0.5 g),
- vertically up to 0.3 times the mass of the load (0.3 g) (which encourages the displacement of the goods).

The time for which the above forces are exerted is approx.  $\frac{1}{10}$  second (acceleration measurements filtered at 15-20 Hz). Where securing devices are dimensioned by calculation, these forces should be considered quasi-static for the purposes of securing goods.

The lateral and vertical forces exerted on the goods during transit are caused by vibrations at 2-8 Hz.

According to EN 16860, Appendix B, the proof of safety can be demonstrated by using the following methods:

- 1) calculation based on the aforementioned acceleration values; **or**
- 2) impact- or, running- or, bench tests; **or**
- 3) approved computer-supported simulations.

### 1.4 Goods forming the load

The loading guidelines and examples distinguish between:

- bulk goods (gravel, scrap iron, waste, wood chippings, etc.),
- individual objects (vehicles, crates, machinery, combined transport units<sup>1)</sup>, etc.),
- objects assembled to form load units and behaving like individual objects during transit (packages, bundles, bales, bound stacks, etc.)

Inside the transport units (wagons, containers, etc.) the goods must be:

- uniformly distributed,
- secured against movement and being blown away or lifted by the wind,
- protected, when fragile, using suitable materials.

For the purpose of combined transports of liquid products in tank-containers, intended for the carriage of substances in the liquid state, shells which are not divided by partitions into sections of not more than 7 500 litres capacity, shall be filled to not less than 80% or not more than 20% of their capacity.

This rule does not apply to liquid products with a kinematic viscosity of at least 2680 mm<sup>2</sup>/s at 20°C, or to molten substances with a kinematic viscosity of at least 2680 mm<sup>2</sup>/s at the filling temperature.

When loading dangerous goods, the shipment-specific instructions<sup>2)</sup> must be observed, especially those relevant for the use of packaging and tanks.

Viscous goods in tank-containers/tankwagons (e. g. slurry, kaolin, etc.) shall be transported under special transport conditions due to their nature (e. g. min. 80 % or max. 20 % of their capacity).

The relevant provisions from volume 1 shall apply by analogy to the loading and securing of goods inside vehicles on wheels or caterpillar tracks and inside combined transport units, which must be properly suited to the type of goods to be carried. An exception to this principle is loading with the possibility of sliding, which is not permitted inside vehicles on wheels or caterpillar tracks or inside combined transport units.

<sup>1)</sup> Only approved intermodal transport units may be carried exclusively on carrier wagons used in combined transport.

<sup>2)</sup> See the version of the RID in force as well as ADR regulations in case of combined transport.

## 1.5 Formation of load units

Goods may be assembled to form load units using:

- bindings made of steel strip, iron wire, synthetic or woven straps that must be tensioned, with a breaking strength (straight pull)<sup>1)</sup> of at least:
  - 500 daN for palletised goods weighing up to 500 kg,
  - 700 daN for palletised goods weighing over 500 kg, square sawn timber (rough sawn), wooden boards and edge sawn timber, cellulose bales, etc.
  - 1000 daN for sawn timber (planed wood), wooden sleepers, stone or concrete slabs, etc.
  - 1400 daN for packages and coils of sheet steel (individual coils), bundles of steel pipes, steel profiles and bars, coils of wire rod, steel strip, steel billets, stacks of plywood and hardboard slabs, blocks of stone, etc.
  - 2000 daN for binding together several sheet steel coils,
  - 4000 daN for binding together steel pipes, where a dovetailed layer is resting on a scotched layer.

The number of fastenings – at least two – uniformly arranged, shall depend on the properties of the goods in question. At least four fastenings shall be used to bind several coils of steel sheet together.

The use of steel strips for binding stacked packages of square-sawn timber, wooden boards and edge-sawn timber (formation of stacks) in load units is not permitted on open wagons due to the special risk of accident posed by the potential tearing of the strips.

- shrink-fit or stretched plastic sheeting (for palletised goods the feet of the pallets must be enclosed in the plastic sheeting) must withstand the mechanical stresses and climatic conditions occurring during carriage by rail. If necessary, it must be ensured that the sheeting can withstand the effects of biological conditions (micro-organisms, insects, etc.).

## 1.6 Friction

The friction conditions between the load and the loading surface are decisive when securing the load. The decisive parameter to evaluate the securing of the load is the friction coefficient  $\mu_{GL}$  only, it is calculated for the friction torque formed by the load and the loading surface or between the loads themselves. In the rest of the document this coefficient shall be named friction coefficient  $\mu$ .

When using anti-skid materials, it is advisable to choose the optimum technical solution to obtain the highest possible friction coefficient – ideally  $\mu \geq 0.7$ .

---

<sup>1)</sup> When using polyethylene (PET) straps the securing point must have a strength amounting to at least 80% of the breaking strength (straight pull).



## 2 Use of wagons, transport units, and intermodal loading units (ILUs)

### 2.1 General indications

No constructional alterations, such as boring holes, welding on securing devices, cutting off parts with a blow-torch, etc., shall be made to the wagons or transport units/ILUs without the owner's consent.

Any ice or snow must be removed from the loading surface prior to the loading operation.

After loading and unloading:

- doors, walls, roofs, flaps, hatches, valves, etc. must be closed and secured,
- boards (flaps) should be placed in their upright position and boards that are folded down to accommodate the load should be secured, for example using direct fastenings, for boards that do not foul the loading gauge, see table 3. Any markings, signs and wagon labels must remain visible,
- other removable and/or movable parts and securing devices (e.g. stanchions) should be immobilised in the equipment or holders provided,
- residue from the load transported, dirt and loose objects (stones, bark, etc.) are to be removed from the wagon,
- any parts used for securing the load (scotches, nails, wire, etc.) are also to be removed and the wagon cleaned,
- transport of food or feed may be subject to additional cleaning requirements (e.g. International Database for Transport of Feed and Food (IDTF)),
- security equipment<sup>1)</sup> used to detect unlawful handling of goods (e.g. food or feed) must be implemented after loading and noted on the consignment note.

After loading, stanchions should in principle be placed in the upright position (except for carriage of combined transport load units loaded on flat wagons with spigots).

After unloading, the end board stanchions are always to be placed in the upright position.

When, with the agreement of the forwarding RU, removable or movable wagon/ILU parts are exceptionally not placed in their usual position, they must be stowed in such a way that they do not jeopardise operating safety.

### 2.2 Floor

Goods liable to damage the loading surface because of their small bearing surface, their shape or mass should be loaded on timbers or bolsters. These are required when the load acting on the wagon floor exceeds the following values:

- 10 kg/cm<sup>2</sup> for wagons with the UIC marking,
- 5 kg/cm<sup>2</sup> for other wagons.

For road vehicles loaded on flat wagons, 5000 kg per wheel are permitted without timbers or bolsters.

The maximum permissible load exerted on the floor by industrial handling machines is:

- 3000 kg per wheel in the case of wagons,
- 2760 kg per wheel in the case of containers. Any two bearing points of the load must be at least 760 mm apart.

### 2.3 Walls, sides and doors

Goods that are in contact with the walls and sides must not exert a force that may cause damage to these wagon parts or that may jeopardise operating safety during transit.

Sliding doors and walls, hatches and roofs must not be obstructed by the load. It must be possible to open them without risk. Sliding doors and walls may only be used for load securing purposes within the limits of their strength. The goods in contact with them must not be allowed to tip or roll against them.

The load may not lie on top of the walls or sides. Only stacked load units that are in contact with the stanchions (logs, etc.) may lie on the walls.

### 2.4 Sheeting devices

Wagon sheets are used to protect goods against the weather and are not suitable for securing purposes. In order to ensure unobstructed opening and closing of the sheet, it should not be allowed to come into contact with the goods.

---

<sup>1)</sup> Seals, padlocks, etc.

## 2.5 Stanchions

Goods that rest on the stanchions must not exert a force on either the stanchions or their holders such that permanent deformation results. Stanchions may move from the vertical position because of the play in their holders. Swivelling stanchions should, if necessary, be secured using hardwood chocks before loading wagons.

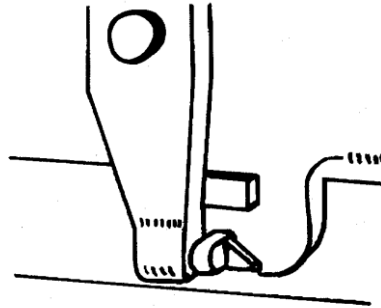

- ① Where cylindrical goods are loaded in stacks or in dovetailed formation and lean against the removable stanchions so that they protrude by more than half their height, facing stanchion pairs should be joined together with bindings. The bindings used must have a breaking strength of at least 1000 daN.

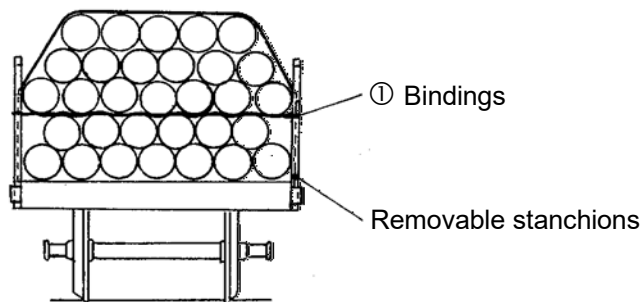

When fastening a load directly or indirectly, the fastenings may only be attached to the stanchions if the stanchions are secured against lifting.

## 2.6 Securing devices (rings, hooks, eyelets)

For the direct or indirect fastening of goods, use should be made of securing rings, eyelets or hooks made of steel rod with a diameter of at least 16 mm. Direct fastenings may be used between two securing points facing each other for loads of:

- up to 10 t for flat wagons,
- up to 5 t for covered wagons.

The eyelets and rings designed for securing sheets on wagons can also be used as follows:

- for the direct fastening of goods weighing up to 2 t,
- for the indirect fastening of goods weighing up to 4 t.

The breaking strength of the securing points must be equal to that of the fastenings (several securing points may be used if necessary). If several fastenings are used, the strength of each fastening must be at least the same as that of the securing point.

If there are no conveniently placed securing points, the fastenings may be attached to suitable parts of the wagon. However, it is not permitted to attach fastenings to parts of the running gear or suspension, nor to the bogies, signal brackets, door closing/locking devices, handrails, steps, etc. Fastenings must not be looped around the buffing, the draw gear or the braking gear and the underframe.

## **2.7 Built-in load securing equipment**

### **Partition walls**

Partition walls serve to secure part-loads. Between partition walls, measures to secure the load against tipping lengthways in the wagon can be reduced or even done away with entirely.

In standardised wagons, up to 5 t may be loaded against one partition wall, i.e. in a compartment formed by the partition walls, and up to 7 t may be loaded against two partition walls that are locked in place one directly against the other. In this configuration, the load must be in contact with the partition walls over a surface at least 2400 mm wide and 700 mm high.

### **Loading cradles**

Cradles are generally used for loading coils of steel sheet. They are also suitable for loading similar types of goods, such as cable drums. The permissible diameters and masses must be observed for the individual cradles. Existing fittings for lateral scotching (retaining arms) should be placed in active position and as close as possible to the coils once the cradles are loaded.

### **Indirect fastening equipment**

Indirect fastening equipment is generally used for securing pipes, rough logs and square-sawn timber. The straps must be tensioned after loading and unloading or must be stowed safely when not in use.

### **Wheel scotches**

Wheel scotches are used to secure vehicles. They are arranged on the loading surface lengthways in the wagon so as to move or lock into position. When vehicles are being secured, the wheel scotches should be applied as close as possible to the tyres. After unloading they should be safely stowed.





### 3 Wagon loads

#### 3.1 Line categories

The lines of each railway are classified into categories per the permissible mass per axle and mass per linear metre, as follows:

Line category	Maximum mass per axle	Maximum mass per linear metre
A	16 t	5.0 t/m
B1	18 t	5.0 t/m
B2	18 t	6.4 t/m
C2	20 t	6.4 t/m
C3	20 t	7.2 t/m
C4	20 t	8.0 t/m
D2	22.5 t	6.4 t/m
D3	22.5 t	7.2 t/m
D4	22.5 t	8.0 t/m
E4	25 t	8.0 t/m
E5	25 t	8.8 t/m

Each RU designates a standard line category that corresponds to the majority of its lines open to international traffic<sup>1)</sup>.

Special agreements may be concluded between RUs for specific traffic flows, lines or wagons. Similarly, the wagon loads for domestic traffic flows can be covered by special rules.

NB<sup>2)</sup>: In accordance with the WAG TSI and EN 15528: on category C lines, a mass per axle of 20 t may be exceeded by 0.5 t per axle on wagons with a "D" load plate in the following exceptional cases:

- long wagons with two axles with 20 t mass per axle and 14.10 m < length over buffers < 15.5 m in order to increase their payload to up to 25 t;
- wagons designed for mass per axle of 22.5 t in order to offset the additional weight so as to enable full use of this mass per axle.

The maximum mass per axle is 11.1 t.

In the case of newly built wagons constructed and approved in accordance with the WAG TSI, account is made of this rule in the load plate for category "C".

#### 3.2 Load limits

The load limits are marked on the wagon. The load limit to be considered is that resulting from the lowest line category on the route in question. This limit must not be exceeded.

#### Example

	A	B1	B2	C2	C3 C4
S	00,0	00,0	00,0	00,0	00,0
SS	00,0				

		C	D
ÖBB	S	00,0	00,0
DB	000	00,0	00,0
SNCF FS CFL	000	00,0	00,0

Example of inter-RU agreement

<sup>1)</sup> The lines used by RUs are published on the UIC website (LOCA).

<sup>2)</sup> Special national arrangements must be observed.

### 3.3 Distribution of the load

The load should be distributed as evenly as possible on the wagon, without exceeding the maximum mass per axle.

The load distribution should be such that the following ratios are not exceeded:

- for 2-axle wagons: ratio of 2:1 between the masses per axle,

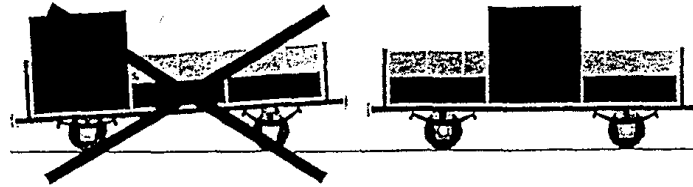

Calculation of the ratio of masses per axle:

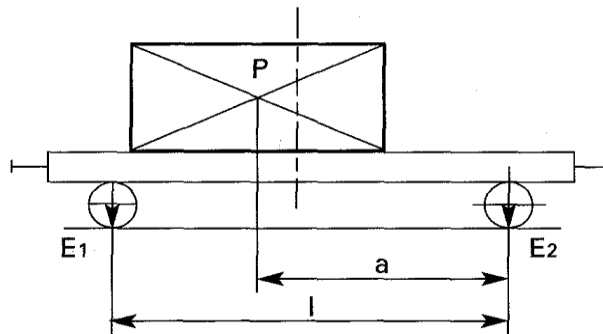

$$E_1 = \frac{P * a}{l} + \frac{T}{2}$$

$$E_2 = \underbrace{(P + T)}_{\text{Total gross mass}} - E_1$$

Total gross mass

P = mass of the load unit in t

T = wagon tare in t

E<sub>1</sub>, E<sub>2</sub> = mass per axle in t

a, l = distances in m

**Example:**

$$E_1 = \frac{20 * 4.5}{8} + \frac{12.2}{2} = 17.35 \text{ t}$$

$$E_2 = (20 + 12.2) - 17.35 = 14.85 \text{ t}$$

Ratio of masses per axle:

$$\frac{E_1}{E_2} = \frac{17.35}{14.85} = \frac{1.17}{1} < \frac{2}{1}$$

P = 20 t

T = 12.2 t

a = 4.5 m

l = 8 m

**Conclusion:**

This consignment can be accepted since the ratio of masses per axle is less than 2:1. However it cannot be accepted on category A lines, as the mass per axle (E<sub>1</sub>) is greater than 16 t.

- for bogie wagons: ratio of 3:1 between the masses per bogie,

**Calculation of the ratio of masses per bogie:**

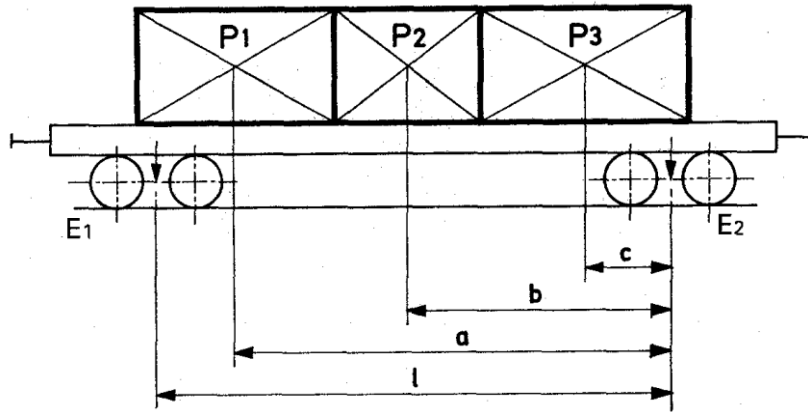

$$E_1 = \frac{(P_1 * a) + (P_2 * b) + (P_3 * c) + T}{2}$$

$$E_2 = (P_1 + P_2 + P_3 + T) - E_1$$

Total gross mass

$P_1, P_2, P_3$  = masses of each load unit in t  
 $T$  = wagon tare in t  
 $E_1, E_2$  = mass per bogie in t  
 $a, b, c, l$  = distances in m

**Example:**

$$E_1 = \frac{20 * 11.5 + 8 * 7 + 2 * 2.5 + 24}{2} = 34.38 \text{ t}$$

therefore 17.19 t per axle

$$E_2 = (20 + 8 + 2 + 24) - 34.38 = 19.62 \text{ t}$$

therefore 9.81 t per axle

$P_1 = 20 \text{ t}$   
 $P_2 = 8 \text{ t}$   
 $P_3 = 2 \text{ t}$   
 $T = 24 \text{ t}$   
 $a = 11.5 \text{ m}$   
 $b = 7 \text{ m}$   
 $c = 2.5 \text{ m}$   
 $l = 13 \text{ m}$

Ratio of masses per bogie:

$$\frac{E_1}{E_2} = \frac{34.38}{19.62} = \frac{1.75}{1} < \frac{3}{1}$$

**Conclusion:**

This consignment can be accepted since the ratio of masses per bogie is less than 3:1. However, it cannot be accepted on category A lines, as the mass per axle (of bogie E<sub>1</sub>) exceeds 16 t.

- ratio of 1.25 to 1<sup>1)</sup> between the wheels (left/right) of a given axle.

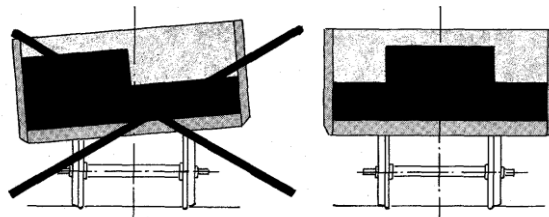

<sup>1)</sup> The permitted limit values for the differences between wheel loads are complied with when the centre of gravity of the load is transversally distant from the centre of gravity by no more than 10 cm approx. when the wagon is fully loaded, 15 cm approx. when the wagon is half loaded

**Calculation of the maximum offset for the centre of gravity of the load across the wagon:**

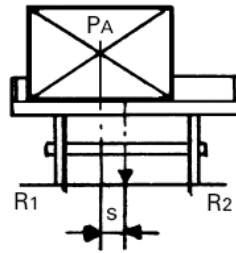

- R<sub>1</sub>, R<sub>2</sub> = Load per wheel in t
- E<sub>1</sub>, E<sub>2</sub> = Load per axle or per bogie in t (calculate as per case 1 or case 2)
- T = Wagon tare in t
- P<sub>A</sub> = Mass of the load on the axle or bogie in question, in t =  $E_1, E_2 - \frac{T}{2}$
- s = Distance of the load unit centre of gravity from the wagon's longitudinal centreline, in m
- Q = Load in t as per table of load limits for the line category to be considered
- M = Gross mass of the wagon (T + Q)

**Condition**

$$\frac{R_1}{R_2} \leq \frac{10}{8} \quad \boxed{s \leq \frac{1}{12} \left( 1 + \frac{T}{2 * P_A} \right)}$$

**Sample calculation of the ratio of loads per wheel:**

Load mass: P<sub>1</sub> = 22 t, P<sub>2</sub> = 10 t, P<sub>3</sub> = 15 t

The calculation may be performed for a wheelset as long as the goods are loaded symmetrically relative to the wagon's longitudinal centreline.

The position of the centre of gravity for each load unit must be determined across the wagon. In this instance, the intervals selected are **a=400 mm**, **b=500 mm**, and **c=1550 mm**.

Four-axle wagon with tare mass T = 22 t

$$\sum M_{R_2} = 0 = R_1 * L - \frac{P_1 * c}{4} - \frac{P_2 * b}{4} + \frac{P_3 * a}{4} - \frac{T}{8} * L$$

$$R_1 = \frac{\frac{P_1 * c}{4} + \frac{P_2 * b}{4} - \frac{P_3 * a}{4}}{L} + \frac{T}{8}$$

$$R_1 = \frac{5,5 * 1550 + 2,5 * 500 - 3,75 * 400}{1500} + \frac{22}{8} = 8,27 \text{ t}$$

$$R_2 = \frac{P_1}{4} + \frac{P_2}{4} + \frac{P_3}{4} + \frac{T}{4} - R_1$$

$$R_2 = (5,5 + 2,5 + 3,75 + 5,5) - 8,27 = 8,98 \text{ t}$$

$$\frac{R_1}{R_2} = \frac{8,27}{8,98} = \frac{1}{1,09} < \frac{1}{1,25}$$

The R<sub>1</sub>/R<sub>2</sub> ratio is lower than 1:1.25. This consignment is therefore **acceptable**.

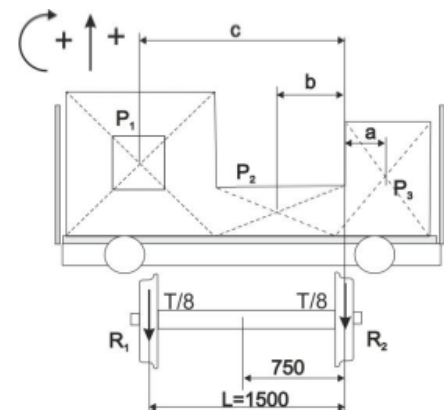

### 3.4 Concentrated loads

The maximum permissible concentrated loads are marked on a table affixed to the wagon. They are derived from the position and length of the load (on flat wagons in particular).

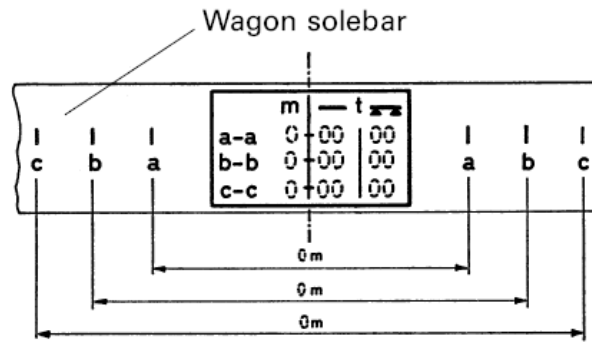

A distinction is made between two types of positioning:

- a) Load resting on the wagon floor, either directly or on at least four timbers placed across the wagon. If the centre lines of the end timbers lie level with or beyond the axles or bogie centres, the bearing length is considered to be the same as the total length of the load.

The maximum load is indicated under the sign **—** opposite the corresponding distance:  
Bearing length = l

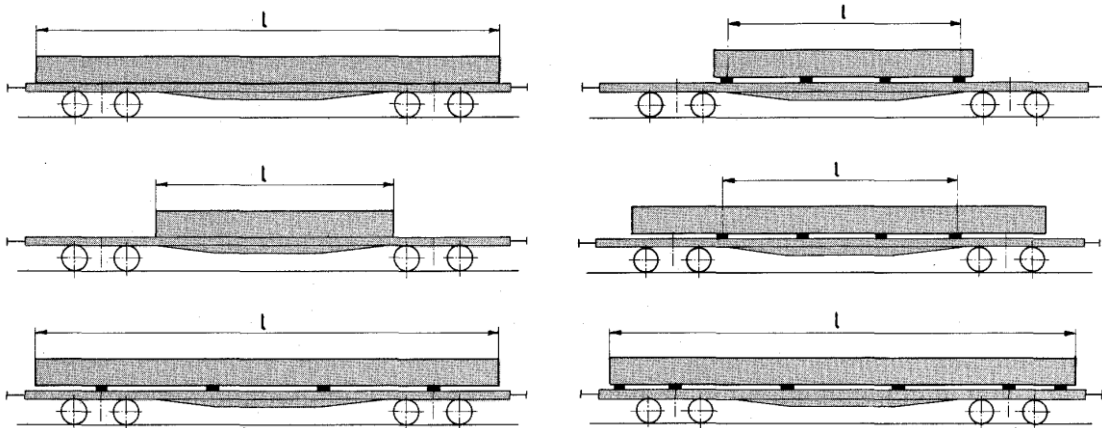

- b) Load resting on only two transverse timbers.

The maximum load is indicated under the sign **▲▲** opposite the corresponding distance:  
Bearing length = l

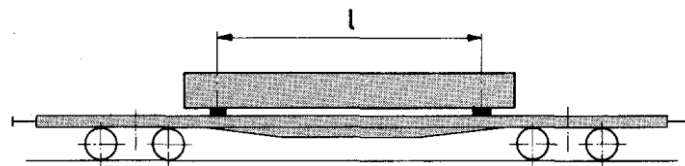

A load of this type lying beyond the axles or bogie centres is only acceptable if there are values indicated in the concentrated load table.

In the absence of the sign **▲▲**, the load may still be placed on two transverse timbers provided the values given for the sign **—** are not exceeded.

When loading vehicles on wheels with several axles, the decisive distance "a-a" is always the distance between the axles of the end wheelsets of the vehicles.

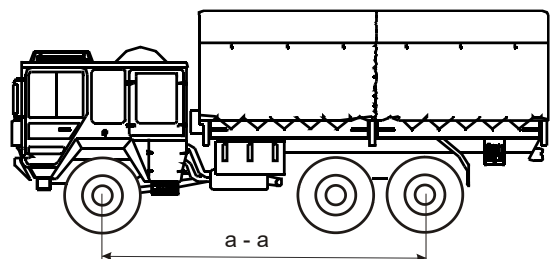

The values indicated in the concentrated load box are calculated for a bearing width of:

- at least 2 m (box with single line border).

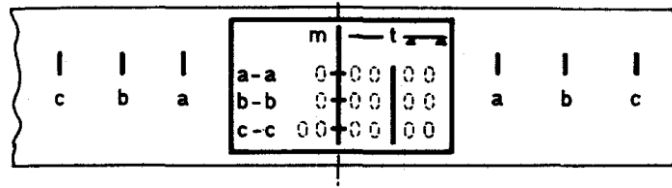

- at least 1.2 m (box with double line border),

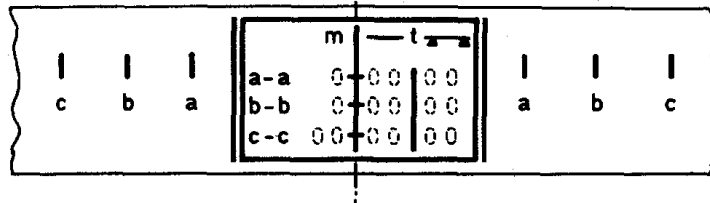

When the ends of the load or the centre line of the end timbers lie between two markers, the permissible load can be calculated by interpolation.

**Sample calculation:**

Permissible mass of a load with 6.5 m bearing length.

A	B1	B2	C
44 t	50 t	52 t	60

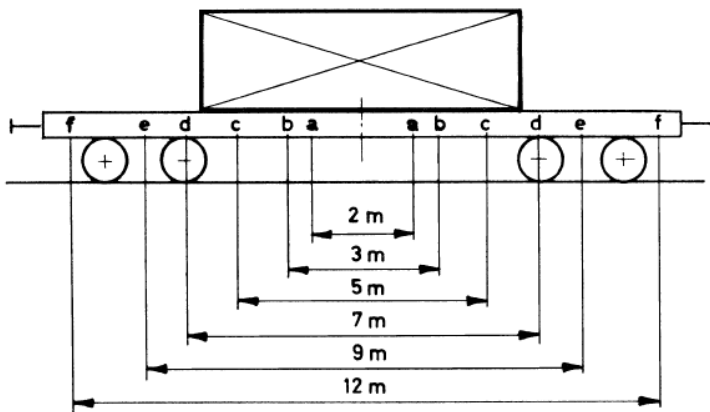

	m	t	
a-a	2	35	40
b-b	3	37	47
c-c	5	43	56
d-d	7	51	58
e-e	9	60	60
f-f	12	60	28

- Difference in length:  $7\text{ m} - 5\text{ m} = 2\text{ m}$
- Difference in mass:  $51\text{ t} - 43\text{ t} = 8\text{ t}$

If the load extends beyond the marker c-c by 1.5 m, the permissible mass for the projecting section is

$$\frac{8\text{ t}}{2\text{ m}} * 1.5\text{ m} = 6\text{ t}$$

The load when resting directly on the wagon floor can therefore have a maximum mass of:

$$43\text{ t} + 6\text{ t} = 49\text{ t}$$

**Sample calculation:**

Permissible load of a mass centred on the middle of the wagon and resting directly on the floor between points a - a (fig. 1).

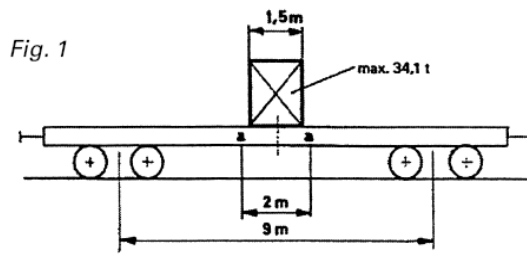

Fig. 2

	m	t	z
a-a	2	35	40
b-b	3	37	47
c-c	5	43	56
d-d	7	51	58
e-e	9	60	60
f-f	12	60	28

As the goods are resting directly on the floor, it is the masses indicated beneath the **—** sign that apply to concentrated masses centred on the middle of the wagon (fig. 2).

For goods loaded between points a - a, the maximum permissible mass is calculated as follows:

1. Take the theoretical permissible mass at the centre of the wagon. This value is calculated by multiplying the mass indicated under the sign a - a (= 35 t) by the corresponding coefficient from the table below.

Distance between axles or bogie centres	a-a												
	6 m	7 m	8 m	9 m	10 m	11 m	12 m	13 m	14 m	15 m	16 m	17 m	
1.5 m	0.88	0.89	0.90	0.92	0.93	0.93	0.94	0.94	0.95	0.95	0.95	0.96	
2.0 m	0.83	0.86	0.88	0.89	0.90	0.91	0.92	0.92	0.93	0.93	0.94	0.94	
2.5 m	0.79	0.82	0.84	0.86	0.86	0.89	0.90	0.90	0.91	0.92	0.92	0.93	
3.0 m	0.75	0.78	0.81	0.83	0.85	0.86	0.88	0.88	0.89	0.90	0.91	0.91	

This gives the theoretical permissible mass at the centre of the wagon:

$$0.89 * 35 t = 31.15 t$$

2. This mass is then incremented by a value which depends on the distance a - a and the length of the goods:

- distance a - a = 2 m,
- length of the goods = 1.5 m,
- difference between the mass a - a **—** and the theoretical permissible mass at the wagon centre

$$35 t - 31.15 t = 3.85 t$$

$$\frac{3.85 t * 1.50 m}{2 m} = 2.89 t$$

The maximum permitted load for this mass resting directly on the wagon floor is therefore:

$$31.15 t + 2.89 t = 34.04 t$$

3. In this instance, there is no restriction in relation to the line category (fig. 3).

Fig. 3

	A	B	C
s	44,0	52,0	60,0

**Sample calculation:**

Permissible load of a mass resting on two supports between points a - a and centred on the wagon's longitudinal axis (fig. 1).

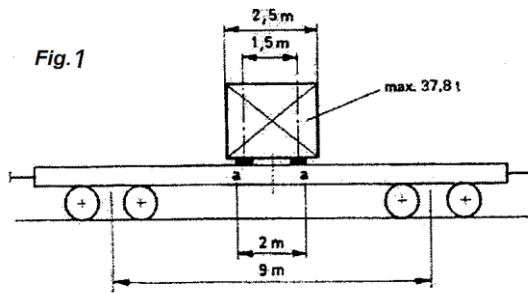

Fig. 2

	m	t	z
a-a	2	35	40
b-b	3	37	47
c-c	5	43	56
d-d	7	51	58
e-e	9	60	60
f-f	12	60	28

- As the goods are resting on two supports, it is the masses indicated beneath the sign  $\blacktriangle \blacktriangle$  that apply to concentrated masses centred on the middle of the wagon (fig. 2).
  - The length of the bearing surfaces to be considered is the measured distance between the centre lines of the two supports.
  - Since the supports are lying between points a - a, the maximum permissible mass is calculated as follows:
1. Take the theoretical permissible mass at the centre of the wagon. This value is calculated by multiplying the mass indicated under the sign a - a (= 40 t) by the corresponding coefficient from the table below.

Distance between axles or bogie centres	a-a											
	6 m	7 m	8 m	9 m	10 m	11 m	12 m	13 m	14 m	15 m	16 m	17 m
1.5 m	0.75	0.79	0.81	0.83	0.85	0.86	0.87	0.88	0.89	0.90	0.91	0.91
2.0 m	0.67	0.71	0.75	0.78	0.80	0.82	0.83	0.85	0.86	0.87	0.88	0.88
2.5 m	0.58	0.64	0.69	0.72	0.75	0.77	0.79	0.81	0.82	0.83	0.84	0.85
3.0 m	0.50	0.57	0.63	0.67	0.70	0.73	0.75	0.77	0.79	0.80	0.81	0.82

This gives the theoretical permissible mass at the centre of the wagon:

$$0.78 * 40 t = 31.20 t$$

2. This mass is then incremented by a value which depends on the distance a - a and the length of the loaded goods:
  - Distance a - a = 2 m,
  - Distance between the supports = 1.5 m,
  - Difference between the mass a - a  $\blacktriangle \blacktriangle$  and the theoretical permissible mass at the wagon centre

$$40 t - 31.20 t = 8.80 t$$

$$\frac{8,80 t * 1,50 m}{2 m} = 6,60 t$$

The maximum permitted load for this mass resting on two supports is therefore:

$$31,20 t + 6,60 t = 37,80 t$$

3. In this instance, there is no restriction in relation to the line category (fig. 3).

Fig. 3

	A	B	C
s	44,0	52,0	60,0



### 3.5 Verification of load distribution

The distribution of the load can be verified by:

- Calculation (cf. paragraph 3.3),
- Weighing the different axles or bogies of the wagon.

The mass of the load is unevenly distributed if:

the distance between rail head and the buffer centre line is less than 940 mm or greater than 1065 mm,

- ① the distance between the spring buckle and the spring stop is less than 15 mm,

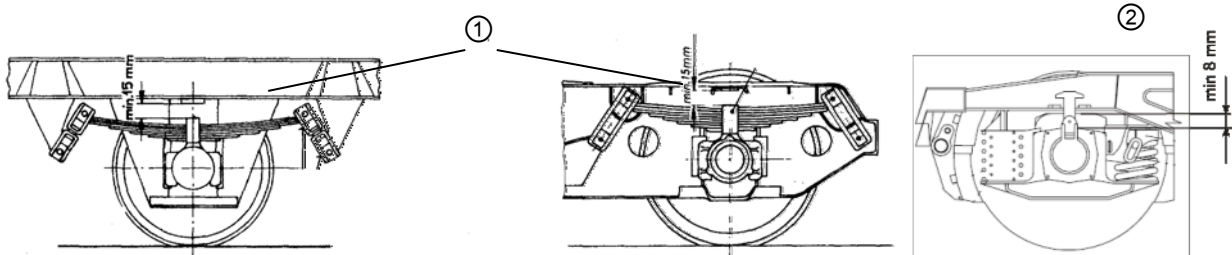

- ② the distance between the axle box and the bogie frame is  $< 8$  mm



## 4 Permissible dimensions of the load

### 4.1 Loading gauges and restrictions

Compliance with loading gauges (tables 1) is required on the railways' lines.

The load must not exceed the smallest loading gauge over the whole of the route. Compliance with this gauge should be measured from rail level on horizontal track on a straight line.

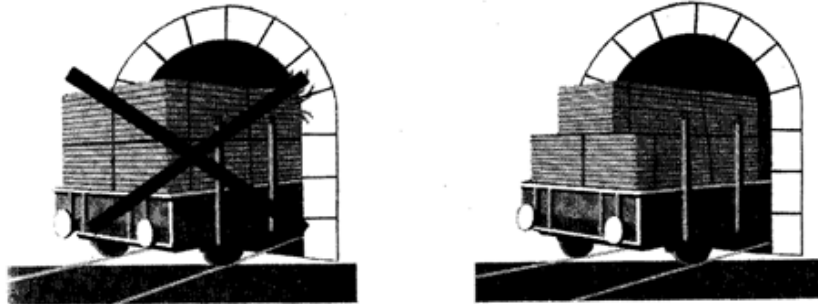

Account must be taken of any restrictions applicable to the width of the load for negotiating curves (tables 2)

- ① on the inside of the curve, between the axles or bogie centres and
- ② on the outside of the curve, as a result of the overhang.

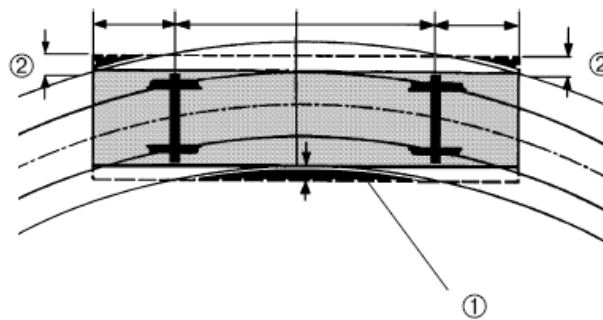

### 4.2 Protrusion of the wagon headstock

The load length marked on the wagon may be exceeded by the following dimensions, as measured from the buffer fastening plane:

- ③ by a maximum of 21 cm
  - ④ up to a height of 2 m above rail level
- and
- ⑤ by a maximum of 41 cm above this height

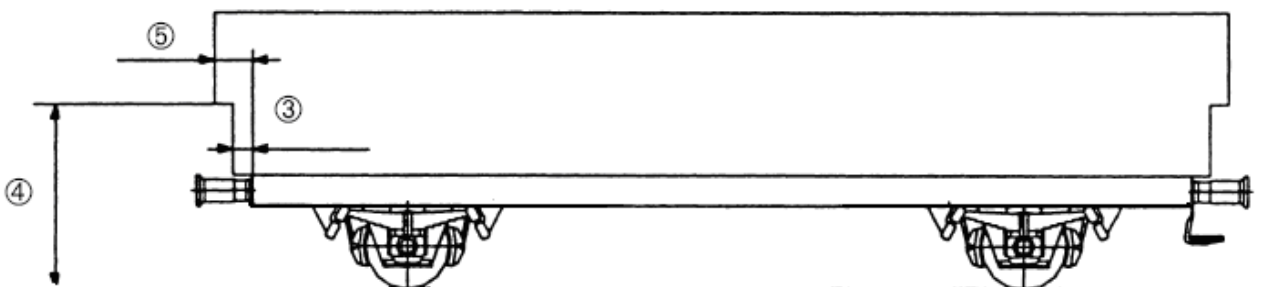

The following clearances must be observed:

- around the draw hook:

⑥ 20 cm on either side of the draw hook and 20 cm above.

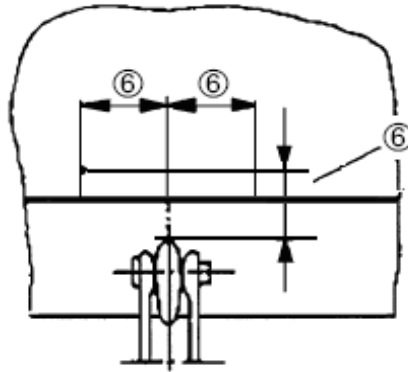

- over the wagon end step:

⑦ 20 cm from the centre of the wagon end step,

⑧ up to a height of 2 m

as measured at the level of the buffer fastenings.

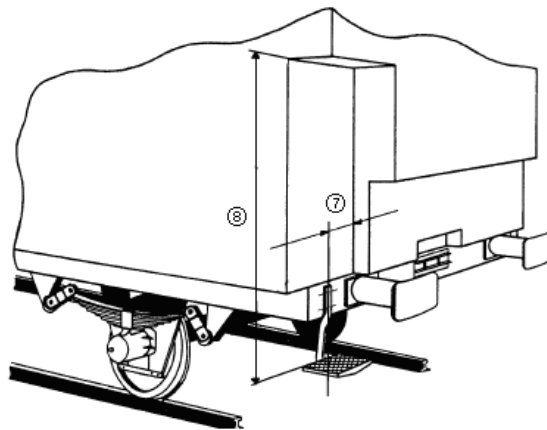

On wagons fitted with shock-absorbers, the areas marked with black and yellow stripes must also remain clear.

### 4.3 Buffer wagons

A buffer wagon must be used when the load exceeds the prescribed limits set out in paragraph 4.2. The following minimum space should be respected:

⑨ 35 cm between the loads,

⑩ 10 cm between the load and the buffer wagon.

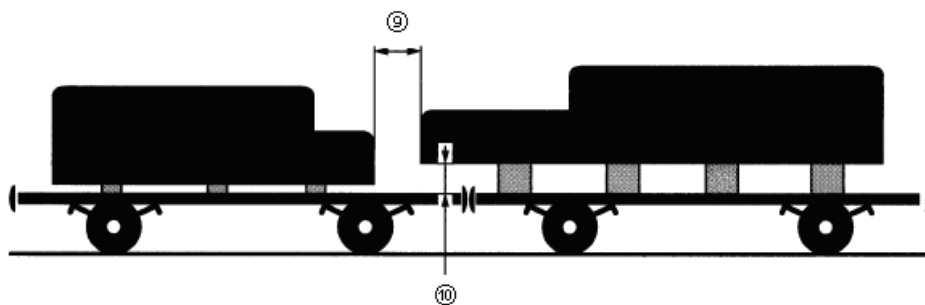

A clearance of 10 cm from the floor vis-à-vis the buffer wagon should be respected when the load protrudes beyond the end axles or bogie centres of the carrier wagon by no more than 6.5 m.

For loads with larger overhang, the values in the table below apply (basis for calculation: profile I100), intermediate values should be determined by interpolation).

Overhang up to	Clearance from the floor
7.0 m	13.0 cm
8.0 m	16.0 cm
9.0 m	19.0 cm
10.0 m	23.0 cm

#### **4.4 Permanently-coupled, multiple and articulated wagons**

##### **4.4.1 Coupled wagon**

A wagon made up of permanently-coupled units or multiple wagons is a set of several underframes that are operated as one. A multiple wagon may be formed from axle or bogie vehicles.

##### **4.4.2 Articulated wagon**

An articulated wagon is a wagon made up of distinct elements with an articulated link between the intermediate running gear. It comprises at least three axles or three bogies.

##### **4.4.3 Single vehicle**

Each set is considered to be a single vehicle for operating purposes. It has a single identification number and carries the markings of a single vehicle, in particular one single load plate per set.

##### **4.4.4 Load limit**

The load limit for each individual element is equal to the total mass entered on the load plate divided by the number of elements making up the set.

Each element must abide by the same rules as a conventional wagon, particularly with regard to the distribution of the load lengthways and crossways in the wagon (see also paragraph 5.9).

##### **4.4.5 Rigid loads**

Rigid loads are subject to the provisions applicable to loads spread over several wagons (see also paragraph 5.9.1).

The load may cover the coupling zone if due account is taken of longitudinal play (see also paragraph 4.3).

The provisions applicable to buffer wagons shall apply by analogy when the load is resting on one element only and extends beyond the coupling zone.



## 5 Methods of loading and securing

### 5.1 Basic principles

The type of goods, the characteristics of the wagon and of the line on which it is to run must be taken into account during loading. Railway operating safety must not be compromised by displacement of the load or its centre of gravity, the influence of wind or the presence of snow or ice on the loading surface or on the goods, etc. The goods must therefore be loaded in a stable position and secured both lengthways and crosswise against lifting, falling, moving, rolling and tipping. Damage must not arise from the way they are positioned or held in place.

Use should be made of the walls, sides, stanchions and other fixing devices built in to the wagon to secure the load. The sides and stanchions should therefore generally be placed in active (raised) position. Where this is not feasible, for example in the case of exceptionally wide loads, the goods must, subject to the agreement of the forwarding RU, be secured using special devices.

### 5.2 Goods loaded in bulk

Goods such as scrap iron, used paper, wood cuttings, stones, etc. must be evenly distributed over the whole loading surface.

#### 5.2.1 Light goods (or parts of them) liable to be uplifted by the effect of moving air, such as:

- Scrap iron such as metal sheets (irrespective of size, surface area and thickness), sections of bodywork, machine punchings, mixture of light and heavy scraps,
- boards, planks and slabs up to 15 mm thick,
- wood chippings,
- bundles of newspapers, old paper in bulk, etc.

- ① should be loaded no higher than the top edge of the walls, including in the centre of the wagon,
- ② wood chippings may also be loaded in a cone formation,
- ③ Goods should be covered over their entire surface (irrespective of the height of the load) as described in paragraph 6.

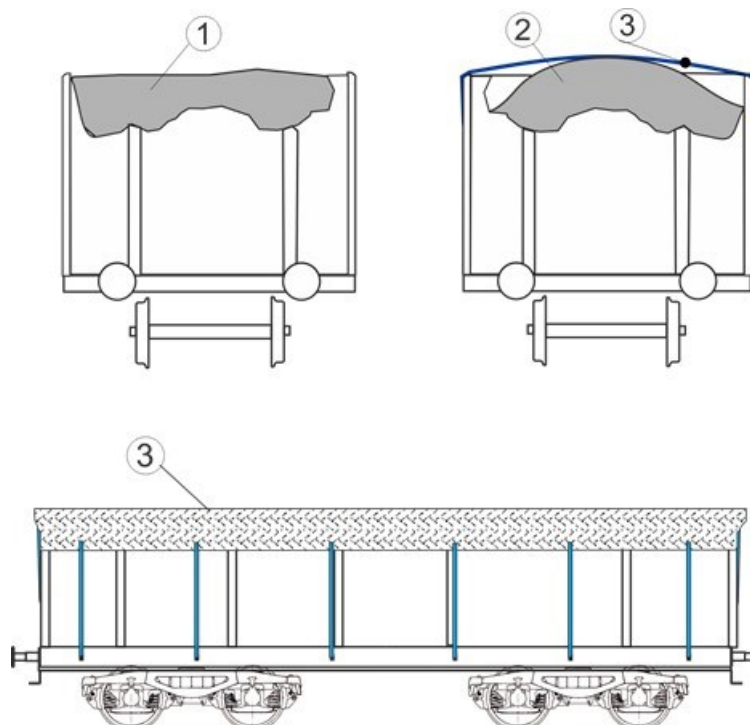

**5.2.2 Heavy goods that are liable to fall from the wagon as a result of vibrations during transit or impacts during shunting, such as:**

- boards thicker than 15 mm,
- heavy scrap such as shredder scrap, cast and wrought iron pieces and fragments, shavings and chippings, stones, etc.

- ① should be loaded up to approx. 10 cm below the top of the sides
- ② Packages of compressed scrap and uncrushed motor cars should be loaded to approx. the top of the sides.

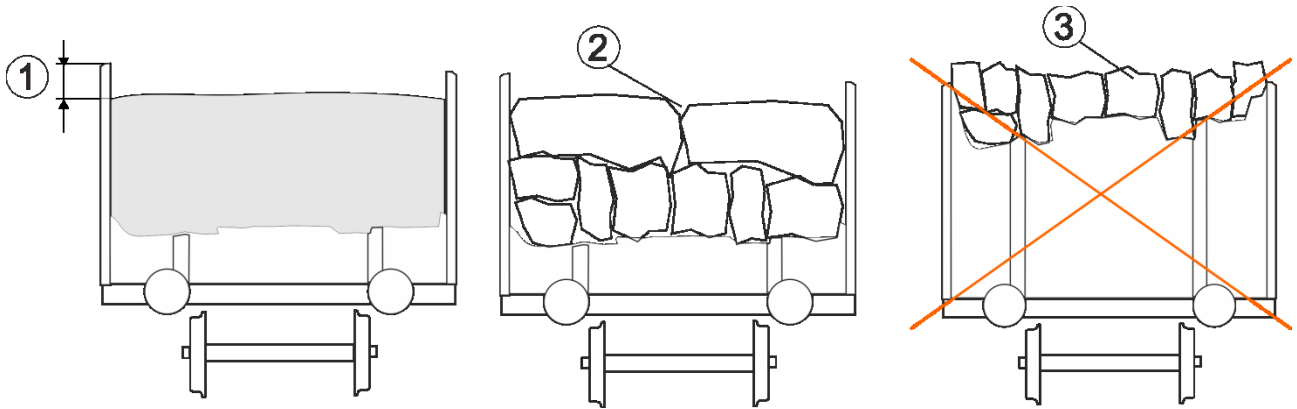

- ③ Light and heavy goods of this kind must not be made to protrude in order to increase the effective height of the walls.



### 5.3 Powdery goods

Goods such as ore, coal, coke, sand, apatite, phosphate, apples, sugar beet, etc. must be evenly spread over the whole of the loading surface.

#### 5.3.1 Goods loaded in ordinary or special wagons

##### 5.3.1.1 Ordinary wagons

Loading in a cone formation:

- ① up to a height of approx. 50 cm,
- ② the goods should be in contact with the wagon sides up to a height of 15 cm from the top.

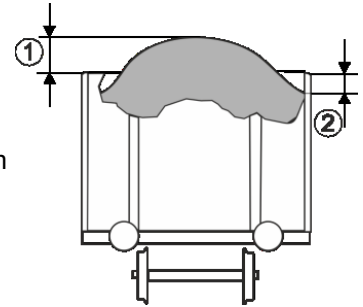

Loading without cone formation:

- ③ up to the top of the wagon sides (including in the middle of the wagon).

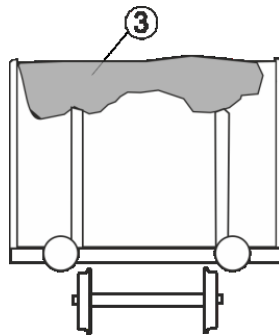

##### 5.3.1.2 Special wagons (fitted with cradles or loading hoppers)

- ④ Cradles and loading hoppers must be filled in a uniform manner both lengthways and crossways.
- ⑤ It is not permitted to fill and/or unload the cradles/loading hoppers on one side only.

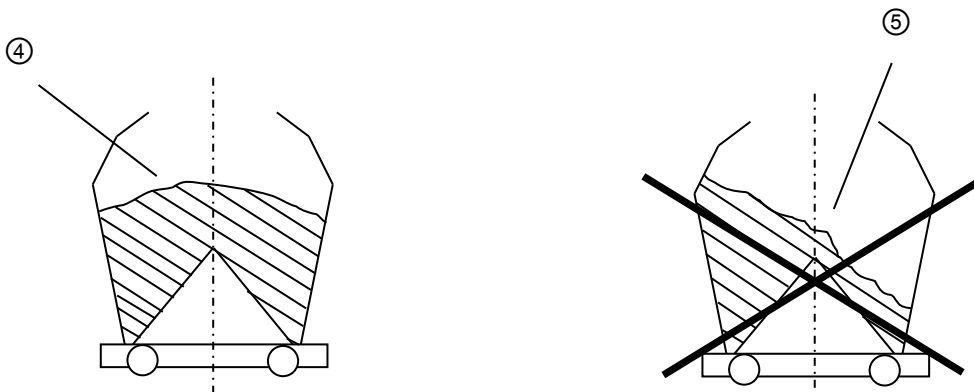

##### 5.3.2 Goods liable to be dispersed by the wind:

- e.g. apatite, phosphate, quartz sand or
- goods subject to the version of the RID in force or
- goods transported under special aerodynamic conditions in long tunnels in accordance with table 5

must be

- loaded in closed wagons or
- completely sheeted over, see paragraph 6.

## 5.4 Goods loaded in compact or rigid formation

Goods that must not be able to move and goods that are able to withstand impacts.

- ① Compact= loading without intermediate space, any remaining gaps filled in
- ② Rigid= goods secured individually or in groups

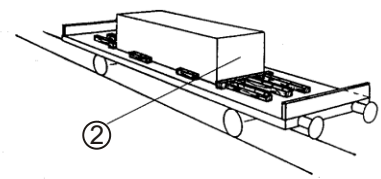
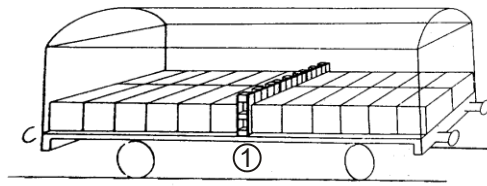

To secure the load, either use wagons with built-in securing devices, for example wagons with lockable partition walls, or adopt one of the following measures:

### 5.4.1 Load secured by the walls, sides or stanchions

Crosswise in the wagon the goods should be in direct contact with the walls, sides or stanchions<sup>1)</sup>.

- ① Parts used to secure the load either lengthways or crosswise in the wagon must have an effective height of at least 10 cm.

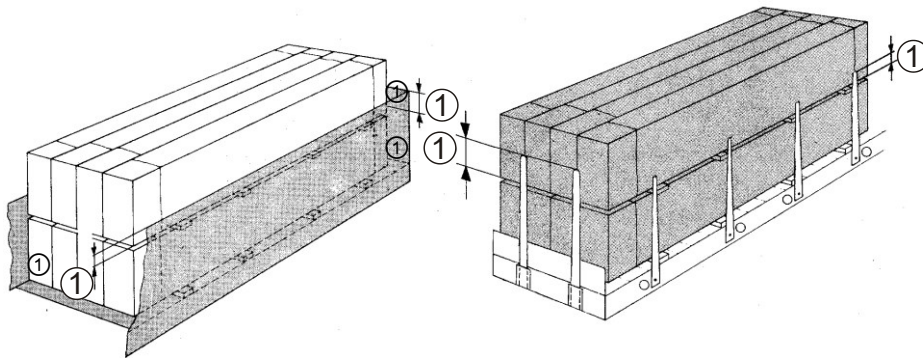

Load units liable to:

- tip must be secured by the sides or walls to at least the height of their centre of gravity,
- roll over the top of the sides or walls must be secured by these sides or walls to at least the height of half their diameter. An effective height of at least 10 cm must be provided.

- ② Where the load is secured using two stanchions only, the goods must extend lengthways above the centre of each stanchion (the centre of the inside stanchion in case of wagons with double stanchions) by at least:

50 cm  
or, if the bearing surface is rough,  
30 cm

30 cm  
or, if the bearing surface is rough,  
20 cm

- ③ The stanchions provided for securing purposes must be positioned at least 80 cm from one another with regard to the stanchions' centre lines.

Logs must in all cases be positioned up to a third of the way from the end of the pile.

If this is not possible, two indirect fastenings must be added, one at either end of the pile, at a distance of approximately 50 cm from the end of the pile (breaking strength at least 4000 daN: straight pull).

- ④ Stable units formed of a single object that are secured at one end only by two stanchions must be secured at the other end using wooden guide-pieces.

<sup>1)</sup> This distance may not exceed 10 cm.

- ⑤ Bound stacks of sawn timber and crates must, if a stanchion is missing, be secured by an additional fastening at the appropriate end.

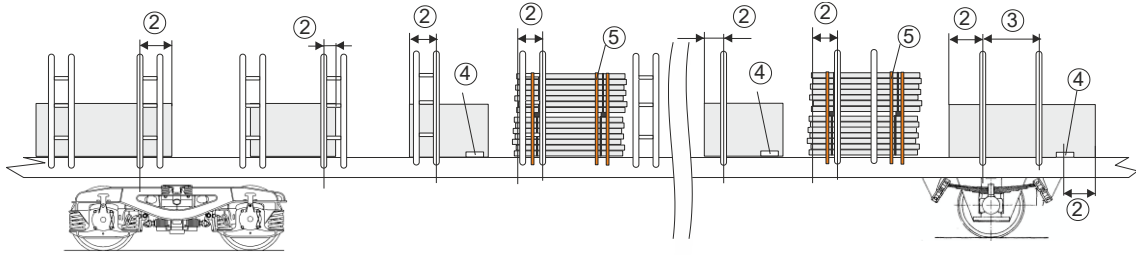

### 5.4.2 Securing the load by filling in gaps and using bracing

- ① To fill in empty spaces, use can be made, for example, of flat pallets (upright) or air cushions. If the gaps to be filled are larger, bracing made of squared timber (at least two timbers in each direction) with a minimum cross-section of 10 x 10 cm is required.
- ② The number of timbers will depend on the mass of the load units and the length of the gap to be filled. For a gap of 2 m and a load of 10 t, for example, the requirement is as follows:

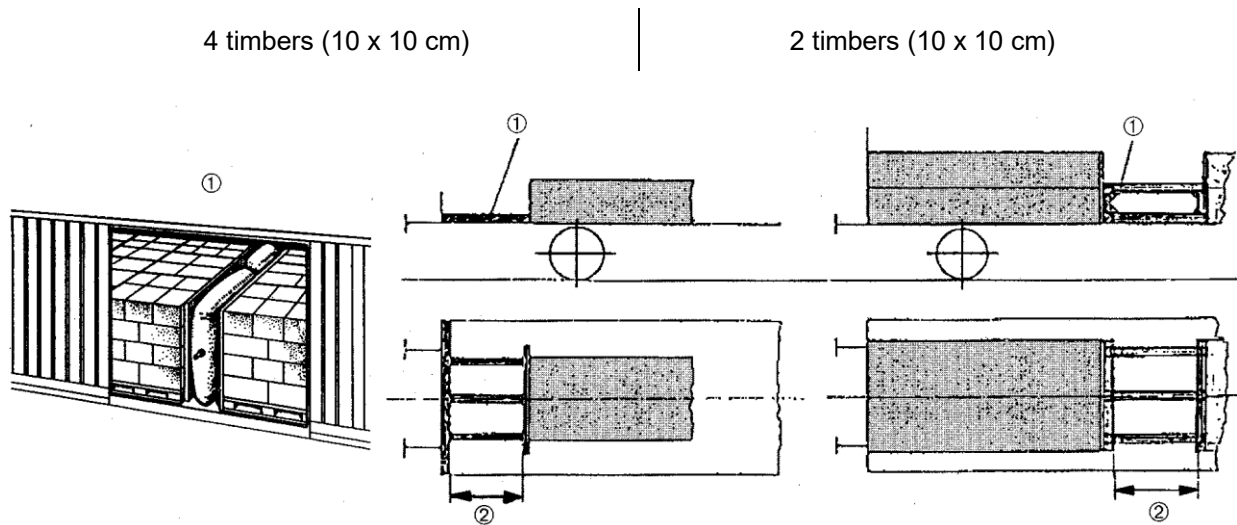

### 5.4.3 Securing using timbers, guide-pieces or scotches

- ① Timbers must be at least 5 cm thick, resting on their broader face and have a right-angled face at the point of contact.

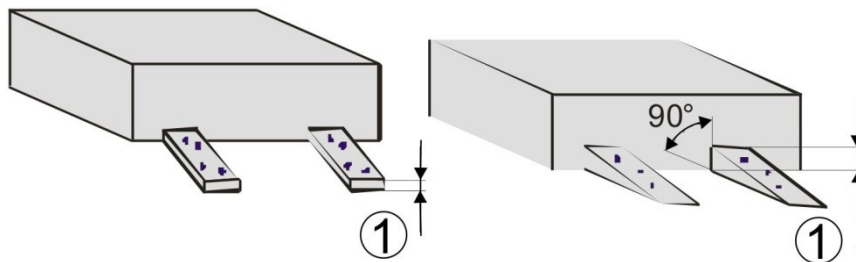

The effective height of the scotches must be at least:

- ② 5 cm to prevent longitudinal movement,  
 ③ 3 cm to prevent lateral movement.

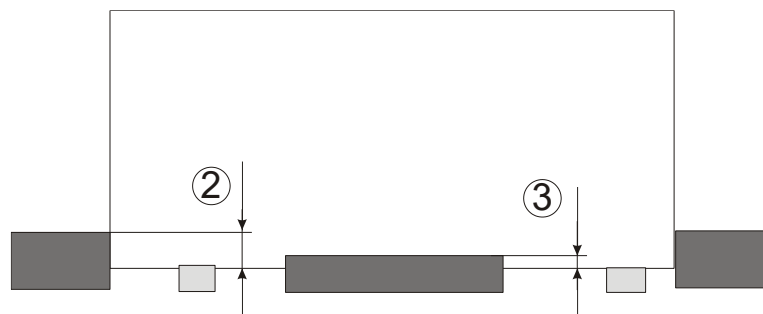

The potential uses of nailed timbers and scotches against longitudinal movement are limited by the maximum mass of the load as follows:

3 t

12 t

The number of nails used, at least two per scotch, is specified in the loading guidelines applicable to the different types of goods and takes account of:

- the mass of the load units to be secured,
- the forces involved,
- the existing friction coefficient.

With nails of approx. 5 mm in diameter and an average friction coefficient ( $\mu = 0.4$ ), load units can be deemed to be sufficiently secured if the scotches are fixed as follows:

- a) **lengthways** in the wagon at both ends and with at least:

1 nail per 100 kg

1 nail per 400 kg

- b) **crosswise** in the wagon on each side and with at least one nail per 1500 kg of the load unit in question.

- ④ Nails must be driven in vertically and as far as possible evenly distributed. They must penetrate to a depth of at least 40 mm into the floor and/or supporting timbers or inserts.

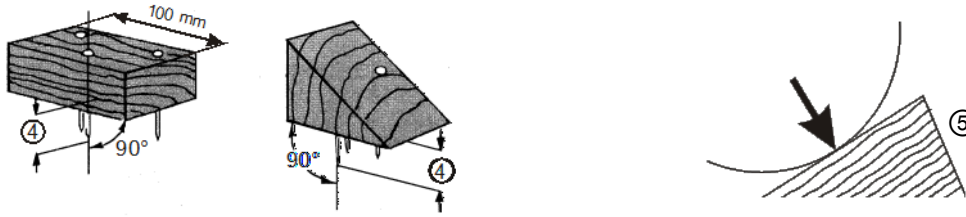

- ⑤ Scotchs must be cut in a way that ensures that stress is exerted across the grain of the fibres.

The number of nails used for a given scotch must be limited, to avoid splitting the wood. For a scotch width of up to 100 mm, no more than three nails should be used. Where necessary, the scotches should be further secured using screws and steel connecting plates.

It is also possible, **in the crossways direction**, to use smaller-diameter nails if their depth of penetration or the number of nails in relation to the mass of load is adjusted accordingly.

Grooved nails can withstand higher extraction forces than smooth nails. In terms of strength a grooved nail of  $d_n = 4.2$  mm is comparable to a smooth nail of  $d_n = 5$  mm.

For **securing goods crossways**, the following table applies:

Type of nail	Nail diameter $d_n$ (mm)	Minimum penetration $s$ (mm)	Mass of load/nail (t)
grooved	4.2	40	1.5
smooth	5.0	40	1.5
smooth	4.6	50	1.5
smooth	4.2	50	1.0

Minimum clearances must be observed between nails and from nails to the edges of scotches/timbers. These clearances depend on the direction of the forces, the grain of the scotch/timber fibres and the diameter of the nails. A wooden scotch with the minimum dimensions of 120 mm high x 80 mm wide can therefore take four nails with about 5 mm in diameter. If the number of nails is greater, the width of the scotch must be increased accordingly.

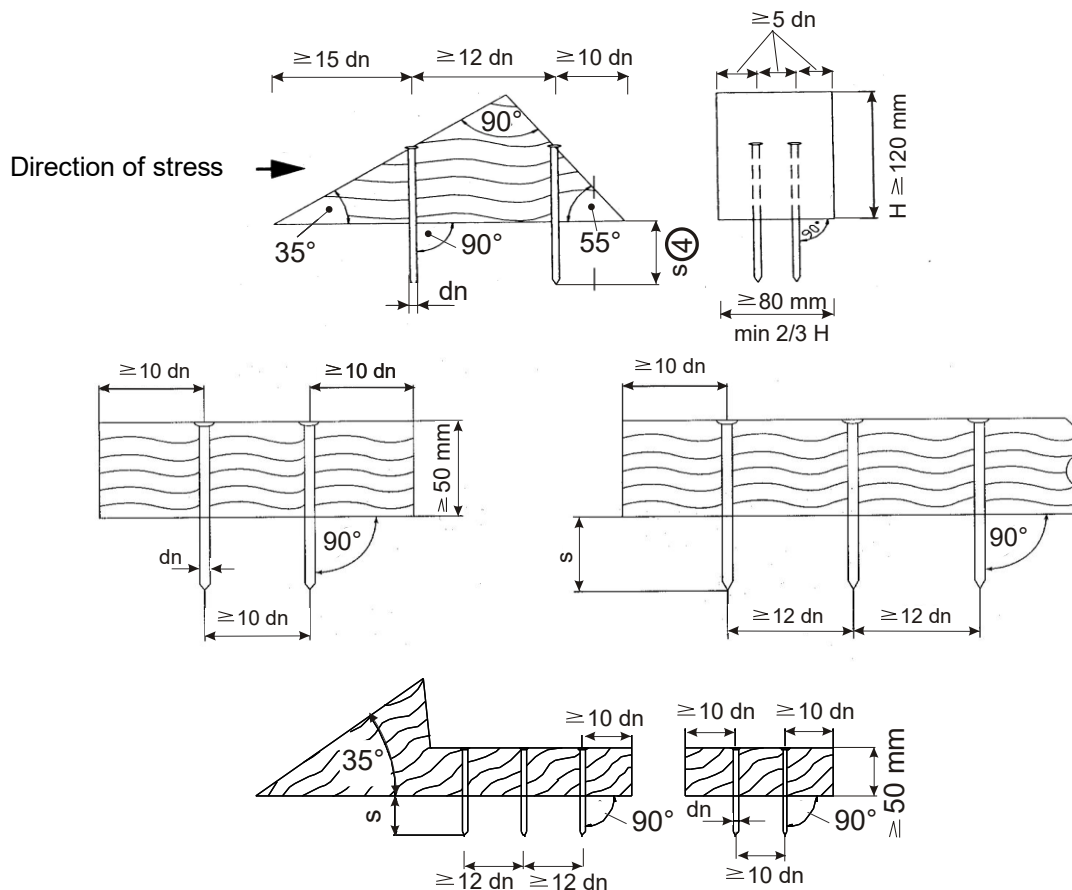

#### 5.4.4 Securing the load by direct fastenings

Direct fastenings act in the direction of the stresses and are designed to resist the movement of the goods.

Depending on the type of goods, their mass and the loading method used, round steel chains, steel cables, woven straps or non-woven straps<sup>1)</sup> may be suitable. Steel strip is not permitted because of the particular risk of accidents in the event of breakage. For goods weighing **up to 3 t**, it is also possible to use annealed steel wire.

Where goods are secured by direct fastening only, the bindings must act both lengthways and crosswise in the wagon. Otherwise, additional securing measures must be taken. In principle, at least two fastenings should be used in each direction.

In principle, the straps used for direct fastenings must be tensioned without twisting, unless the twisting results from the position of the strap and/or the fastening points. In this case the maximum twist is 90°.

The following procedures may be used as means of direct fastening:

- ① Diagonal fastening direct connection with both the wagon and the load,
- ② Loop fastening direct connection with the wagon,
- ③ Head-loop fastening direct connection with the wagon.

For procedures ② and ③ additional securing measures may be required, such as indirect fastenings (see paragraph 5.5.4) or anti-skid strips (see paragraph 5.5.5).

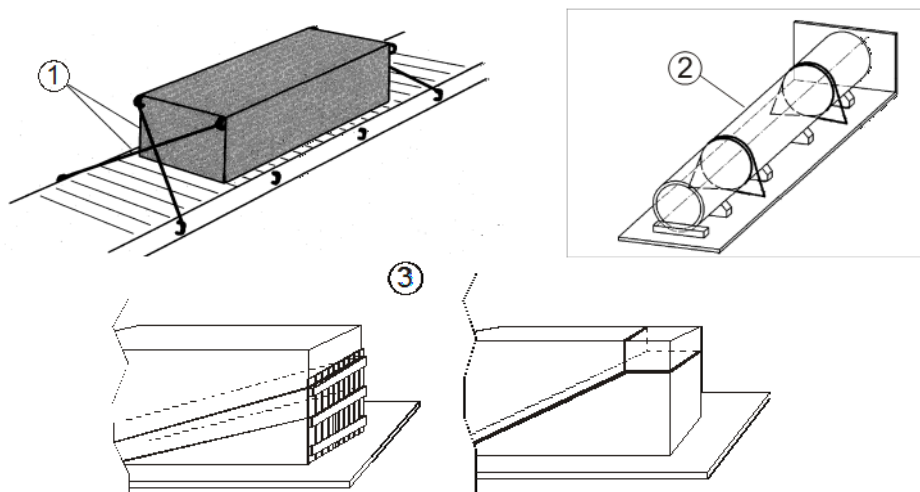

Direct fastenings placed lengthways in the wagon may be considered correctly dimensioned if the breaking strength<sup>2)</sup> (straight pull) of the bindings in each direction is at least:

3200 daN

1000 daN

per 1000 kg of load.

The annealed steel wire must have a diameter of at least 4 mm. Each binding must comprise at least:

4 threads

2 threads

<sup>1)</sup> Non-woven straps, as understood here, are made up of parallel threads with high grade polyester filaments, fully encased in high polymer thermoplastic coating (operational range – 25 °C to + 70 °C).

<sup>2)</sup> The minimum breaking strength (straight pull) is equivalent to twice the tensile force (LC). This only applies to synthetic straps, woven straps and load-securing straps, as well as lashing steel wire ropes and lashing chains.

Chains, steel cables, woven straps and load-securing straps must be used in conjunction with:

- ① an integrated tensioning device **or**
- ② a separate tightening device with lever.

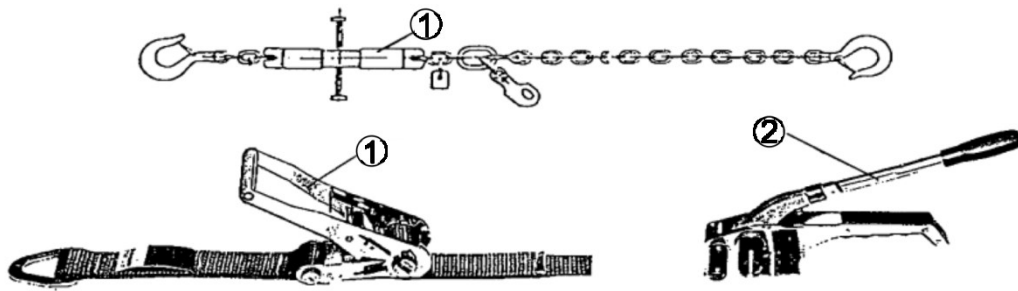

The locks and buckles of the securing straps must be adapted to the type of strap being used in terms of its functional properties and strength.

The bindings must be:

- ③ tensioned as loops **or**
- ④ fixed using hooks. Unless used in closed loading spaces, hooks must be equipped with a guard against unintentional unhooking. Hooks without this protection against unhooking must be held in place at the securing point, e.g. by means of cable ties, wire, etc.
- ⑤ Where there are sharp edges, the straps must be protected by inserts, rubber hosing or edge protections.

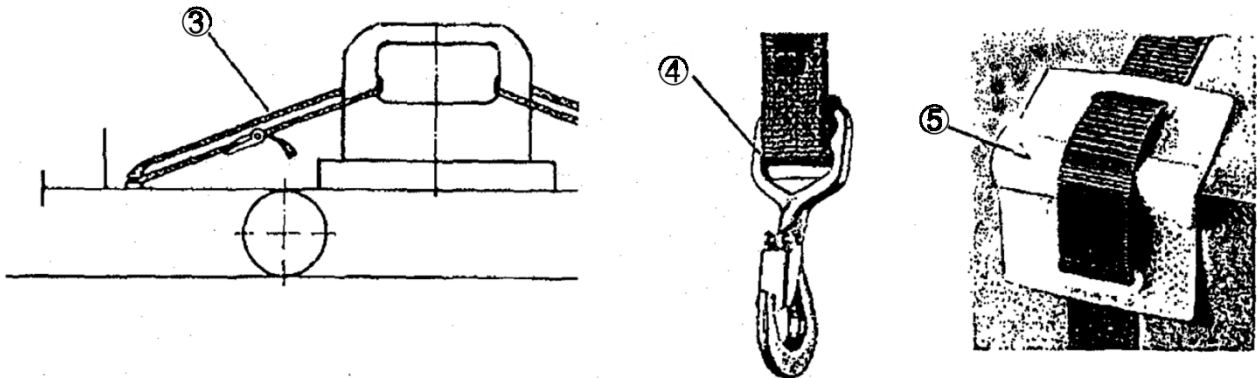

- ⑥ To tension bindings made of annealed steel wire, the wires should be twisted in pairs.

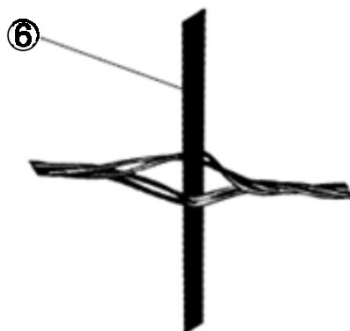

## 5.5 Loading with possibility of sliding lengthways in the wagon

The possibility of sliding should exist in individual wagons and groups of wagons for:

- ① heavy goods that cannot be secured in a compact or rigid arrangement lengthways in the wagon (such as steel billets)

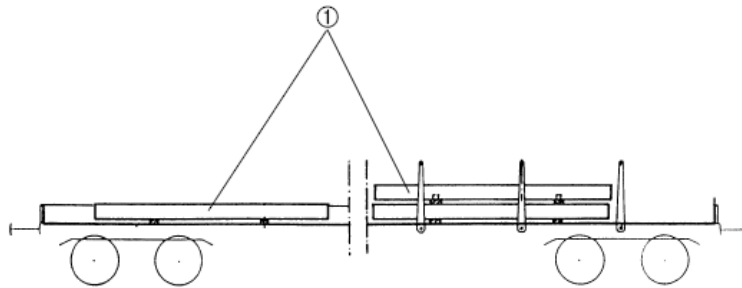

- ② goods that are sensitive to impact, liable to be damaged as a result of the effect of longitudinal stresses (such as machinery).

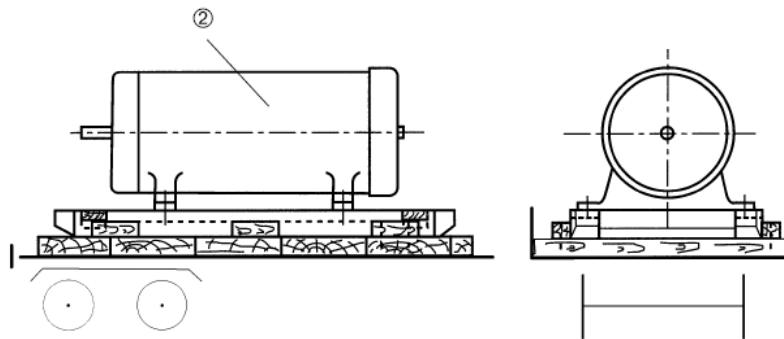

To prevent lateral movement of the load and the resulting encroachment of the loading gauge, and/or to ensure the 1.25:1 ratio between the loads per wheel is not exceeded, the goods should be secured laterally. The provisions of paragraphs 5.4.1 and 5.4.3 should also be observed.

### 5.5.1 Sliding devices

- ① The skids and shoes of trestles should be placed lengthways on the wagon floor; the bottom edges at each end should be chamfered to avoid the trestle becoming snagged on uneven parts of the floor.
- ② The different parts of the trestle should be joined firmly together using tie-pieces or cross-timbers. The latter should be fixed with through bolts or wood screws. If the parts are, exceptionally, nailed together, screw nails should be used, these should penetrate the timbers to a depth of at least 40 mm. The dimensions of these trestles should be set on the basis of the characteristics of the goods.

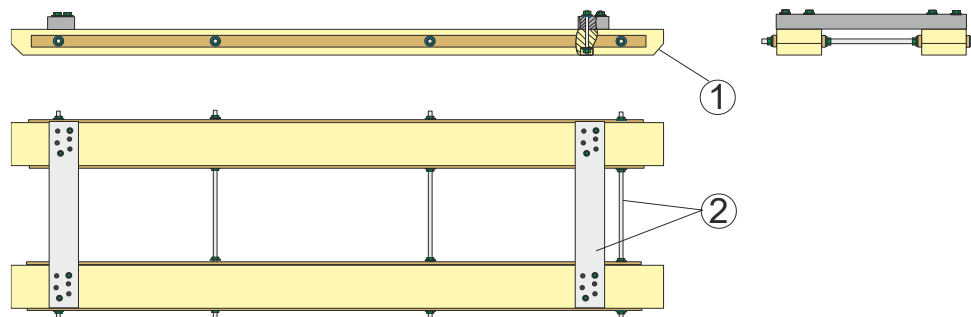

The goods should be fixed to the sliding timbers or trestles such that they are unable to move on it and are not in contact with the wagon floor.

If struts or bracing are used for support purposes, these should be fixed to the sliding timbers or to the trestle.



## 5.5.2 Clearances

① Lengthways in the wagon, the following clearances should be provided at each end:

- at least 30 cm for goods with a rough surface (e.g. blocks of stone),
- at least 50 cm for goods greased or with a smooth surface (e.g. painted steel pipes, steel sections, etc.),
- 100 to 150 cm for goods loaded on timbers, sliding timbers or trestles (e.g. packages of steel sheets, cable drums, machinery, etc.).

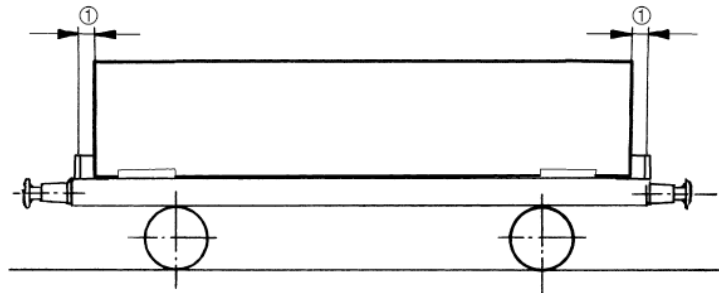

It is permitted for sliding loads to displace lengthways in the wagon under the influence of the stresses caused by carriage, as long as the conditions governing:

- mandatory clearances as per paragraph 4 **and/or**,
- distribution of load as per paragraph 3.3

are met.

The coverage of the supporting scotches and other timbers must be sufficient (protrusion greater than the residual sliding distance).

## 5.5.3 Limitation of sliding distances

Sliding distances must be limited in order to avoid:

- the maximum axle load being exceeded,
- the permissible ratio between the loads per axle or per bogie being exceeded,
- the goods or wagons being damaged,
- the goods encroaching on the clearances required for shunting purposes.

Sliding distances can be limited by the following means:

- indirect fastenings (e.g. woven or synthetic straps),
- timbers or inserts with friction-enhancing capability,
- elastic materials used as cushions in front of the end walls or sides,
- anti-skid packing when the load-bearing surfaces are level. The packing bears the sign indicated by the opposite diagram ①, the head of the arrow indicating the contact surface with a higher friction coefficient.

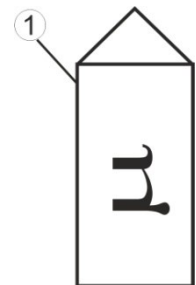

These types of securing can be used individually or in combination.

In some instances, clearance need not be provided when the goods conveyed are not sensitive to impact, for example, steel sections and steel bars, medium and heavy plates, steel billets, round reinforcing bars, bundles of steel tubes and rails loaded on a wagon.

In most cases, these are indivisible goods requiring virtually the entire loading length of a wagon and for which the above-mentioned securing measures are not feasible or can only be applied at disproportionate cost.

In the event of the load being displaced due to impact during shunting and fouling the clearance required for shunting staff, it must be readjusted in the marshalling yard.

#### 5.5.4 Securing the load by indirect fastening

The additional vertical force exerted by indirect fastening increases adhesion and improves the stability of the load units.

The effectiveness of indirect fastenings depends on the following parameters:

- the force of the initial tension,
- the angle of fastening  $\alpha$  (measured between the loading surface of the wagon and the fastening).

The smaller the angle of fastening  $\alpha$ , the greater the force of initial tension must be in order to obtain the same force.

- ① The bindings used should be preferably woven or load-securing straps. These must have an integrated tensioning device or a separate tightening system.
- ② Each load unit must have at least two indirect fastenings applied approx. 50 cm from the ends of the load.

The breaking strength (straight pull)<sup>1)</sup> of the bindings depends on the mass, the length and the surface of the goods: 1000 daN to 4000 daN, with an initial tension meeting the requirements set by the manufacturer. Steel strip may not be used because of the particular risk of an accident in the event of a breakage.

The buckles and locking devices on the securing straps must be suited to the type of strap used in terms of its functional properties and strength.

The bindings must, as far as possible, be fixed using hooks or tensioned in loops (loops double the breaking strength). Unless used in closed loading spaces, hooks must be equipped with a guard against unintentional unhooking. Hooks without this protection against unhooking must be held in place at the securing point, e.g. by means of cable ties, wire, etc.

Use of knots reduces the breaking strength of the bindings by approx. 60 %. If knots are used, the diminished breaking strength must be compensated for by stronger fastenings.

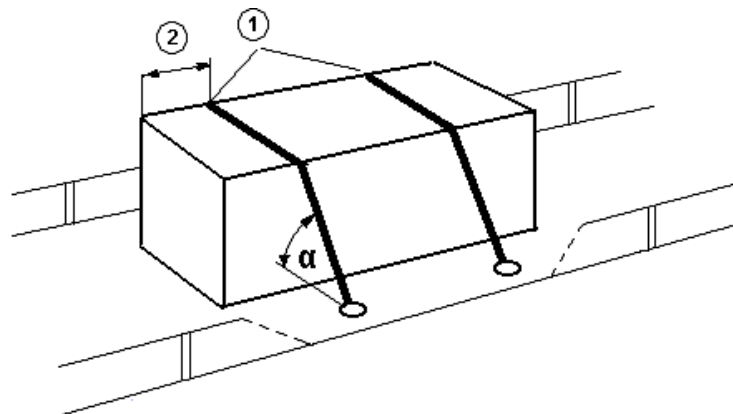

Where there are sharp edges the straps must be protected by inserts, rubber hosing or edge protection (see also paragraph 5.4.4 ⑥).

For goods with a smooth surface or a surface likely to deteriorate, in addition to securing devices it is advisable to use inserts at the ends or between the goods, or packing composed of suitable anti-skid material increasing the friction coefficient and bearing the sign as per paragraph 5.5.3 ①.

The straps used for indirect fastenings and bindings to form load units may be twisted upon tensioning. The total twist on each strap may equal three twists of 360°.

The twist may also be located in those parts of the strap resting on the load, e.g. on the curve of a pile of logs, or over a dovetailed stack of tubing. No twisting of the strap is permitted in edged areas, e.g. packages of sawn timber, girders, wagon sides, etc.

<sup>1)</sup> Minimum breaking strength (straight pull) corresponds to twice the permissible tensile force (LC) and applies solely to synthetic or woven straps and load-securing straps, as well as lashing steel wire ropes and lashing chains.

### 5.5.5 Securing the load by using friction-enhancing materials

It is necessary to distinguish between the different purposes for which anti-skid materials are used – limiting sliding distances, reducing the number of securing measures (number of indirect fastenings), and completely preventing goods from moving (which in practice is only possible laterally).

Subsequently it is advisable to consider on a case-by-case basis whether the available friction torque suits the sought purpose (immobilising the load or limiting its movement).

Anti-skid materials are necessary:

- to reduce longitudinal movement, if for example the load consists of:
  - smooth-coated or greased steel pipes,
  - polished stone slabs,
  - palletised goods loaded on a smooth floor,
  - paper rolls loaded upright or on the roll,
  - coated chipboard panels,
- to reduce lateral movement, if for example the load consists of:
  - paper rolls loaded eye-to-side or upright,
  - coils of steel plate loaded eye-to-side,
  - coated chipboard panels.

Goods secured longitudinally may be secured against lateral movement by means of anti-skid materials used with suitable dimensions.

Anti-skid inserts are not in themselves sufficient to prevent goods from falling from the wagon or fouling the loading gauge. This function is fulfilled, for example, by the walls, sides, stanchions or indirect fastening.

## 5.6 Goods liable to rolling

Goods such as paper rolls, cable drums, wheelsets, other cylindrical load units, vehicles, etc. must be prevented from moving in all directions by fixed walls, sides, stanchions, scotches, trestles or cradles.

### 5.6.1 Centreline placed across the wagon

- goods with an individual or total mass up to 7 t (individual objects loaded side by side or one behind another) may not rest directly on the wagon floor, but should be secured with scotches.
- goods with an individual or total mass up to 10 t must be loaded on trestles. If the trestles are made of wood, they must be firmly screwed in place.
- goods with an individual mass exceeding 10 t must be loaded in wagons or containers fitted with cradles.

#### 5.6.1.1 Individual or grouped loads weighing up to 7 t

Individual or grouped loads must be secured using wooden scotches as follows:

- ① scotch angle of approx. 35° to the goods, up to 45° for vehicles,
- ② scotch height (effective height)  $\frac{1}{8}$  of the diameter, but at least 12 cm,
- ③ scotch width must be at least  $\frac{2}{3}$  of the scotch height,

Goods must be secured in each direction of rolling using:

- ④ at least two scotches or
- ⑤ one scotch of approx.  $\frac{3}{4}$  the length of the load.

Crosswise in the wagon, the goods must be secured using:

- ⑥ timbers approx. 30 cm long and at least 50 mm high or mechanical devices or inserts or anti-skid packing for individual loads weighing up to approx. 2 t.

Timbers must be fixed using nails with a diameter of approx. 5 mm

- in each direction of rolling and with a total of

1 nail per 500 kg

1 nail per 2000 kg

of load

- crosswise in the wagon, use one nail per 1500 kg of load.

The nails must, wherever possible, be driven in vertically and penetrate to a depth of at least 40 mm. They should be evenly distributed on the scotches or timbers, though with at least two nails per scotch or timber. No more than three nails should be used on scotches that are up to 100 mm wide.

Goods must be secured against tipping

- ⑦ when their width is less than  $\frac{5}{10}$  of their diameter (on flat wagons, less than  $\frac{7}{10}$ ), for example by binding the goods assembled to form load units (see paragraph 1.5).

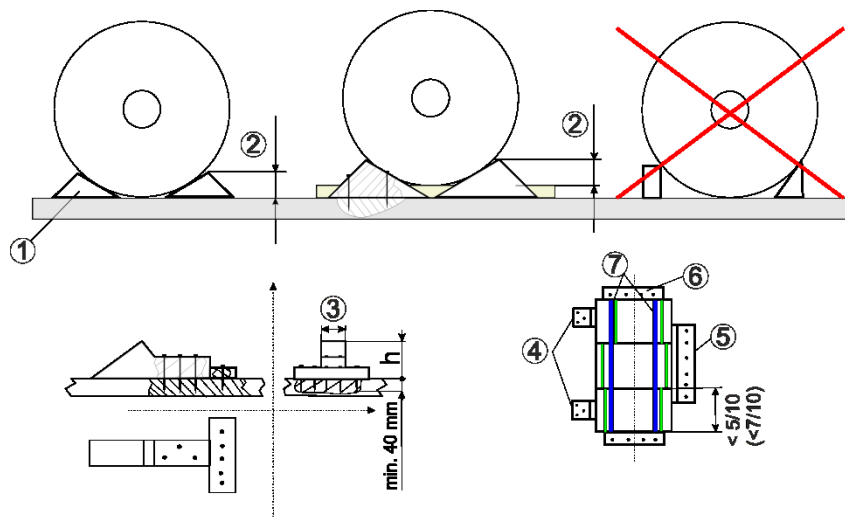

### 5.6.1.2 Individual loads weighing less than or equal to 10 t

Each unit must be secured with two scotches forming a cradle, joined with steel sheeting.

- ① the width of the load must be at least  $\frac{5}{10}$  of its diameter ( $\frac{7}{10}$  on flat wagons).
- ② the goods must not be in contact with the floor, nor be able to move on the scotches.
- ③ scotch angle in relation to the goods: approx.  $35^\circ$ , up to  $45^\circ$  for vehicles.
- ④ scotch height (effective height)  $\frac{1}{8}$  of the diameter, but at least 20 cm.
- ⑤ scotch width:  $\frac{2}{3}$  of the height, but at least 15 cm.
- ⑥ each of the timber scotches must be plated on three sides with steel sheet at least 4 mm thick and screwed in place.
- ⑦ the base plate must be prevented from moving by fitting it with at least six spikes (2x3), 10 to 15 mm long.

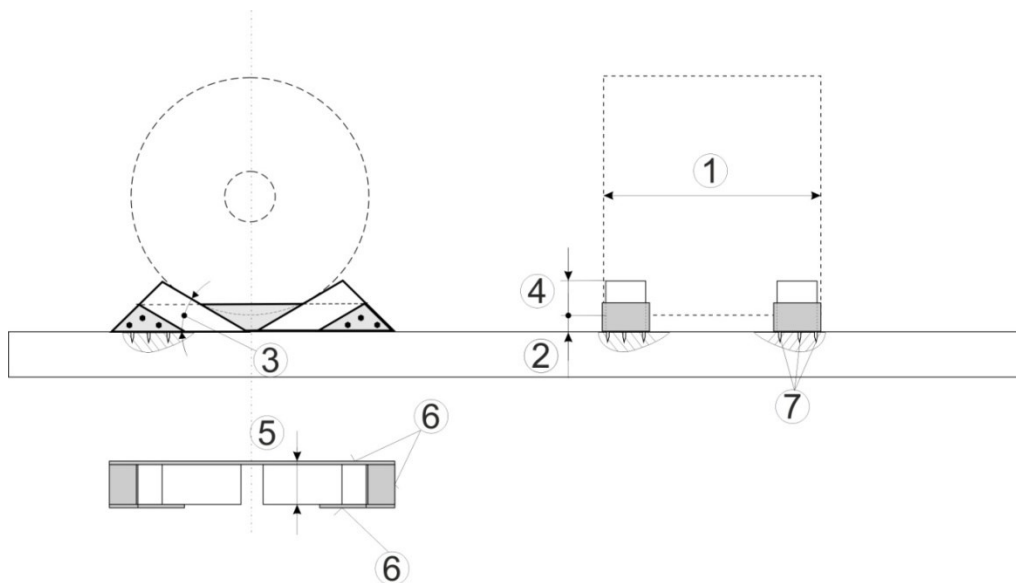

### 5.6.1.3 Individual loads weighing over 10 t

Each unit must be loaded onto wagons or containers fitted with cradles.

- ⑧ The goods must not rest on the floor of the cradle nor be able to move.
- ⑨ The effective height must be at least  $\frac{1}{8}$  of the diameter.
- ⑩ Crosswise in the wagon, the goods must be secured against movement and supported at the level of their centre of gravity to prevent them from tipping, if their width is less than  $\frac{4}{10}$  of their diameter.

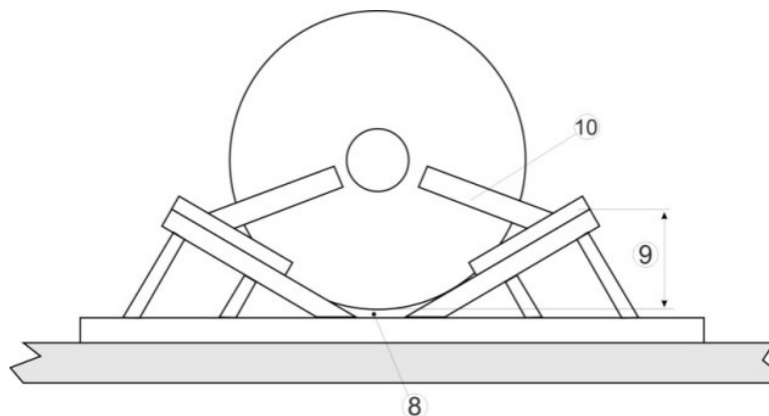

## 5.6.2 Centreline lengthways in the wagon

### 5.6.2.1 Cylindrical goods such as silos, pipes, etc.

Goods resting on the floor, on bolsters or timbers.

The material used for the timbers must be suitable in terms of its quality and cross-section.

Timbers must

- be of a single piece of wood,
- have a rectangular cross-section (height at least 5 cm, width at least 15 cm),
- rest on their broader face,
- cover the whole width of the load,
- be secured against lateral movement (e.g. by nails, scotches, stanchions or sides),
- be inset at least 50 cm from the end of the load and
- be arranged in pairs, their number depending on the mass, length and nature of the goods.

The goods must be secured using scotches with the following dimensions:

- ① scotch angle in relation to the goods approx. 35°, up to 45° for vehicles,
- ② scotch height: at least  $\frac{1}{12}$  of the diameter, but no less than 12 cm,
- ③ scotch width identical to that of the timbers.

The scotches must

- ④ be fixed on the inside and outside with nails of approx. 5 mm in diameter, with a total of one nail per 1500 kg of load, and at least four nails in each direction of rolling.

The nails must wherever possible be driven in vertically (penetrating to a depth of at least 40 mm into the timbers) and be spread evenly over the scotches.

To prevent longitudinal movement, the goods must be either secured at the wagon ends by the walls, ends or stanchions or be secured with at least two indirect fastenings (breaking strength at least 4000 daN) fitted with a tensioning device. A clearance of approx. 50 cm should be maintained from the ends of the goods.

For goods that are stacked, see also paragraph 5.8.

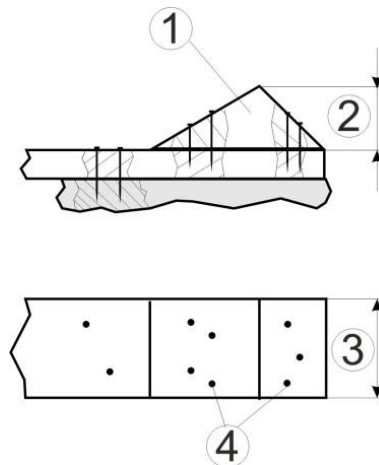

### 5.6.2.2 Cylindrical goods such as coils of steel sheet, cable drums, etc.

The goods should be loaded

- on wooden cradles when their mass, individually or in a group, is less than or equal to 10 t,
  - on metal cradles when their mass, individually or in a group, is greater than 10 t.
- ⑤ The goods must not be in contact with the floor nor be able to move on the trestle.
  - ⑥ Timbers must be firmly screwed in place.
  - ⑦ Effective height of the crib:  $\frac{1}{12}$  of its diameter, but at least 12 cm.

⑧ If the width of the goods is less than:

$\frac{5}{10}$

$\frac{4}{10}$

⑨ of their diameter,

⑩ they must be bound together or supported at the level of their centre of gravity or above.

For securing the cradles and the sliding distances to be respected, see paragraph 5.5.

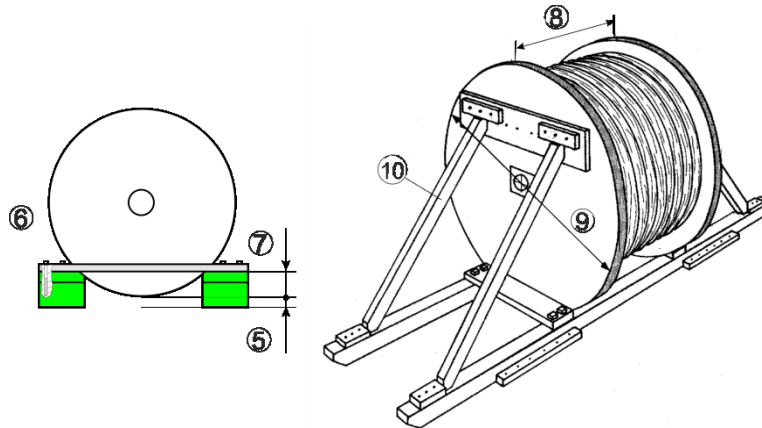

### 5.6.3 Vehicles and machinery on wheels or caterpillar tracks

Vehicles and machinery should be

- loaded lengthways in the wagon,
- immobilised with the hand-brake on and with the first gear engaged or the gears blocked,
- secured against longitudinal and lateral movements either using scotches or by direct fastening.

If it is not possible to immobilise the vehicles and machinery using the hand-brake, engage the first gear or block the gears, both scotches and direct fastenings must be applied. Tyres must be inflated at service pressure.

Sufficient clearance must be left between each vehicle or piece of machinery, to avoid any damage. This clearance shall be determined on the basis of the technical parameters of the vehicles or machinery to be carried.

Additionally, when vehicles or machinery are placed over the articulated link of coupled wagons, account must be taken of the mechanical play between the two elements forming the unit and of the relative movements of the vehicles and machinery in curves.

① Securing with scotches (scotch angle approx. 35°, for vehicles up to 45°) and timbers

- lengthways in the wagon
  - for a mass of up to 6 t using timber scotches (height:  $\frac{1}{8}$  of wheel diameter and at least 12 cm),
  - over 6 t using steel spiked scotches (scotch height: at least 17 cm),
  - number of scotches in each direction of rolling:
 

➤ wheeled vehicles	4	2
➤ caterpillar vehicles and single-axle trailers	2	2
- crosswise in the wagon, on each side (inside or outside):
  - wheeled vehicles secured with two timber scotches,
  - caterpillar vehicles with at least two timbers (height at least: 5 cm).

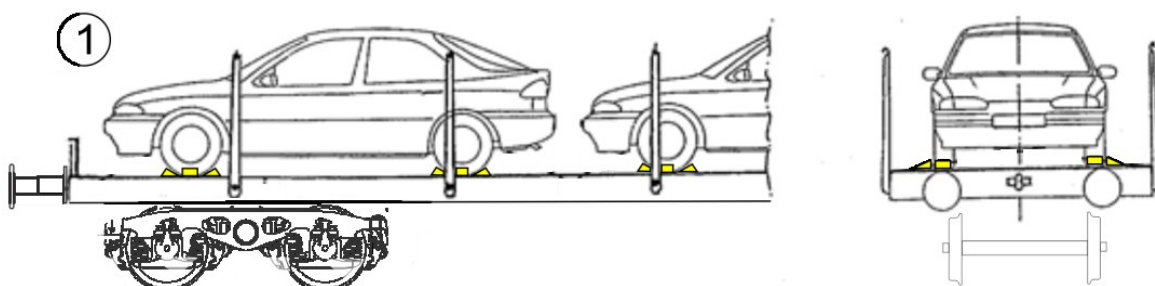

- ② Securing with direct fastenings at both ends of the vehicle using tensioned bindings acting in both longitudinal and lateral directions.

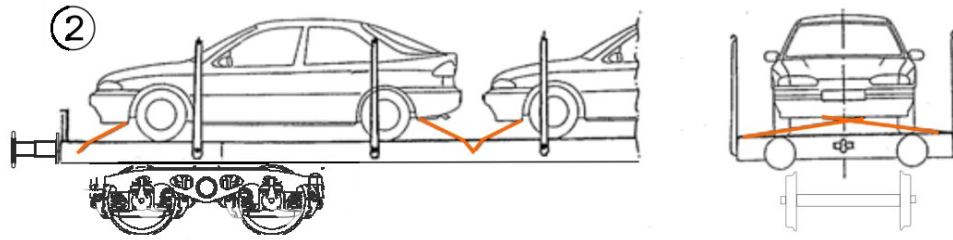

- ③ Heavy vehicles with pneumatic tyres should be scotched using the wagon scotches. The scotches should act in both longitudinal and lateral directions.

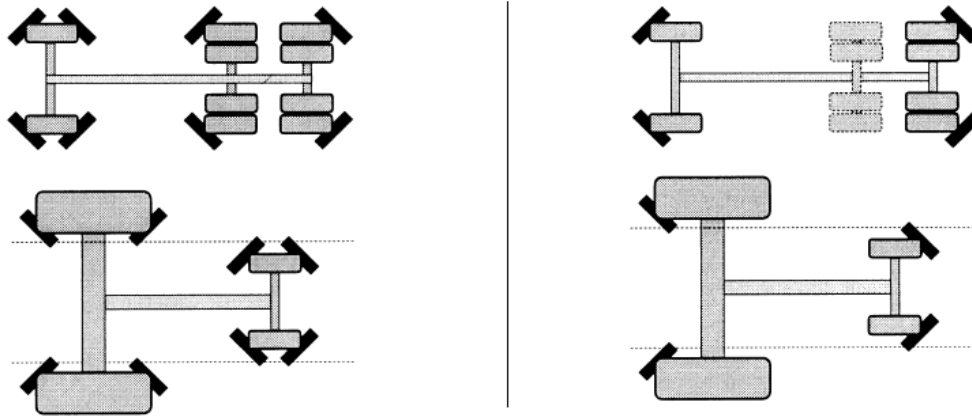

- ④ Light vehicles with pneumatic tyres loaded on car-carrying wagons should be scotched using the wagon scotches. The scotches should act in both longitudinal and lateral directions.

- Scotches on the wheels of one axle

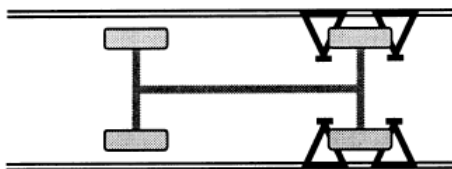

- Scotches in front of the front wheels and behind the rear wheels

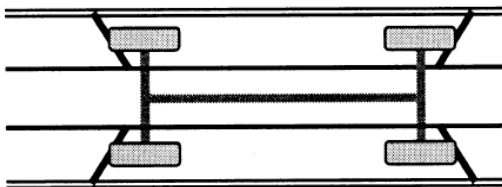

- Scotching of one single wheel is permitted if there are guide-rails at least 50 mm high to prevent lateral vehicle movements that might encroach the most restrictive gauge on the route and if the scotches remain effective in the longitudinal direction

Type a)

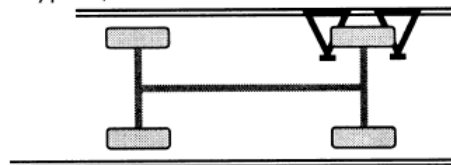

Type b)

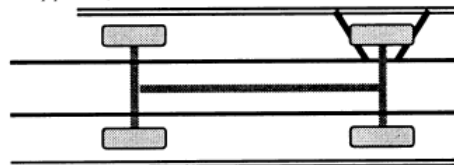



### 5.7 Goods liable to tipping

Free-standing goods (round or angular bearing surface)

- ① with a regular cubic or cylindrical shape,
- ② with an irregular shape (determine the centre of gravity),

must be secured against tipping if the ratios a:h or b:k are less than:

- lengthways (goods fixed or not)

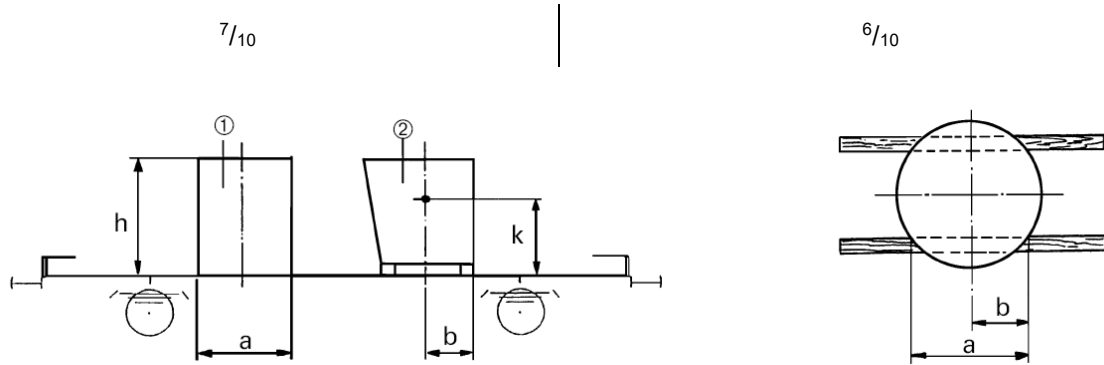

- crosswise <sup>5</sup>/<sub>10</sub>,

<sup>7</sup>/<sub>10</sub> for flat and low-loader wagons, if the ratio of the mass of the load unit to the lateral surface area exposed to the wind (product of the length and the height of the goods) is less than 1 t/m<sup>2</sup>.

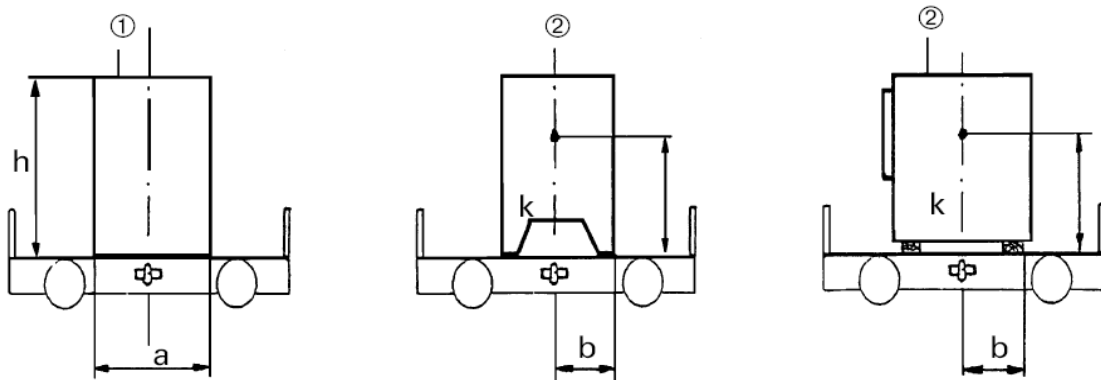

These values shall also apply if goods on cradles, sleds, etc. are bound together to form a single load unit.

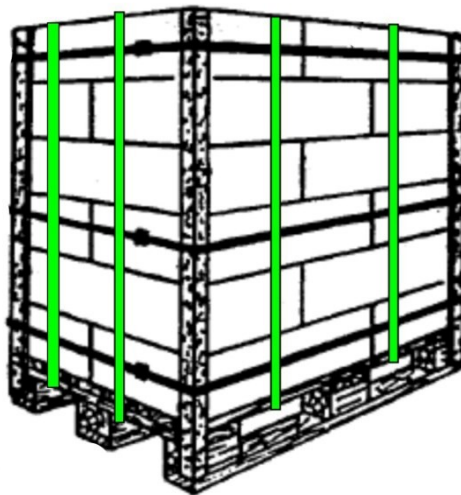

Tipping can also be prevented by

- placing several load units in compact formation and binding together,

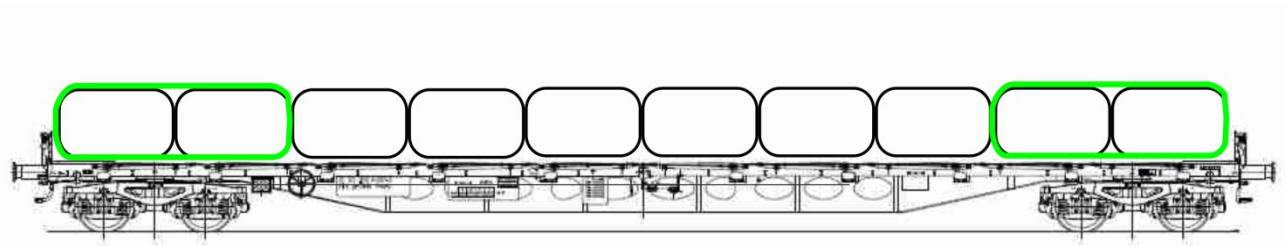

- direct fastening or supporting props,

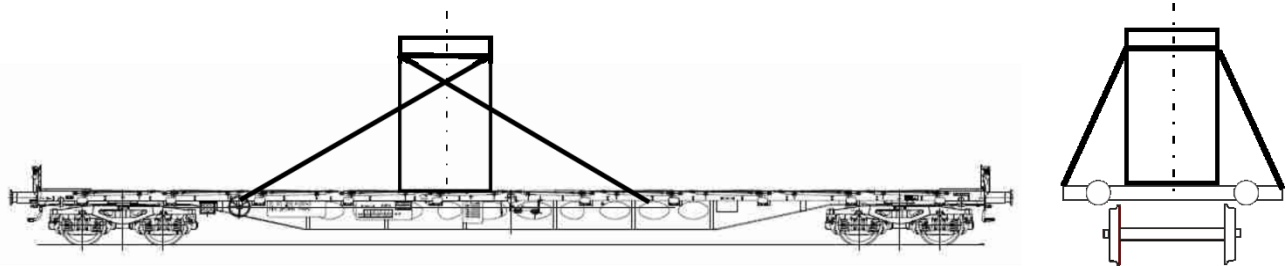

- supporting from beneath using trestles

Trestles must be positioned such that they do not tip, attention should be paid to ensuring that the wagon is not overloaded on one side.

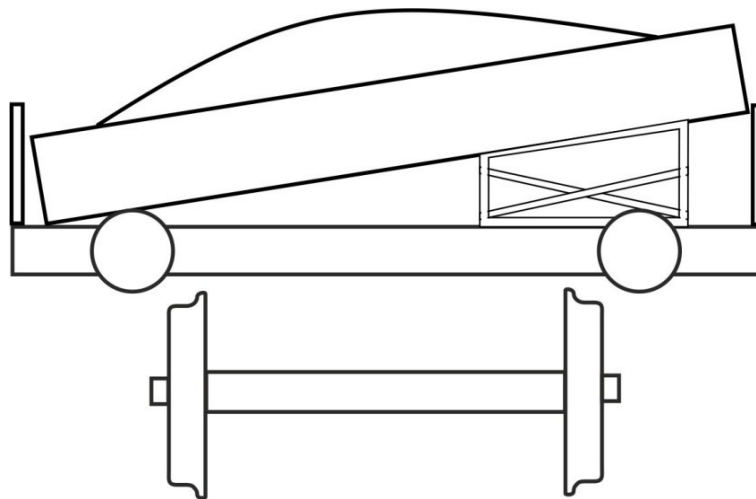

## 5.8 Goods in stacks

- ① The goods must be spread over as much of the available floor area as possible, to keep the stacks as low as possible.

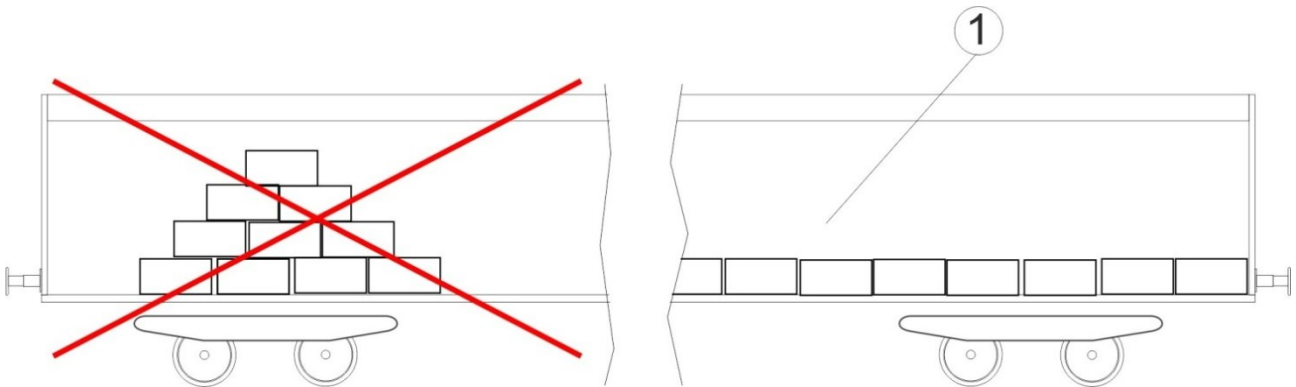

Superimposed units must form stable stacks that must be prevented from falling apart, for example by:

- interlocking different tiers (e.g. for metal bars or sacks),
- using timbers or friction-enhancing inserts (e.g. for slabs, sheet metal, sawn timber, paper rolls),
- using cribs (e.g. for pipes or barrels),
- using shrink-fit or stretched plastic sheeting (e.g. for palletised units),
- binding units together (e.g. for metal sheets, chipboard panels),
- indirect fastening using woven or non-woven straps (e.g. for rough logs).

- ② When the stacks are formed of units of different length and mass, the longer, heavier units or those with a bigger diameter should be loaded at the bottom of the stack. Units that have ends with different masses or thicknesses should be loaded alternately.

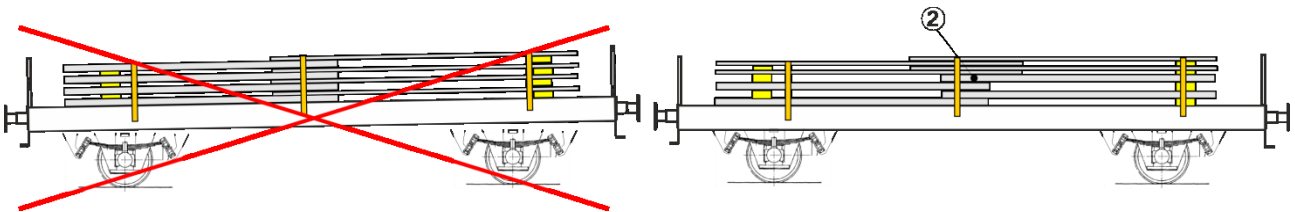

Stacks formed of cylindrical units may be loaded in flat tiers or in dovetailed formation.

- ③ As a rule, timbers should be inserted between the different tiers.
- ④ If the objects loaded in flat tiers are cylindrical, their centrelines must be vertically aligned.
- ⑤ Dovetailing is only permitted if the diameter of the units in the dovetailed tier is no greater than those in the supporting tier immediately below.

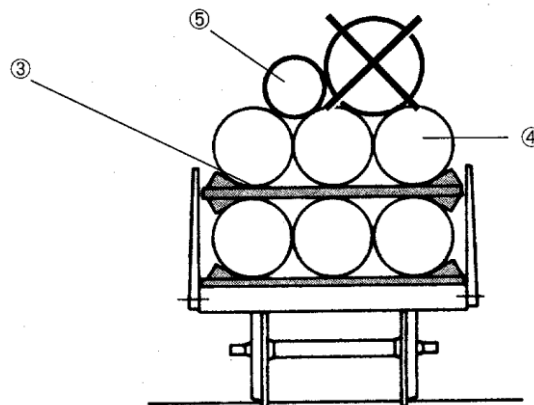

For stacks loaded on flat wagons and liable to sway laterally (e.g. metal trellis-work), the minimum horizontal clearances between the loading gauge and the load should be increased, as shown in tables 2.

- ⑥ In order to avoid loads tipping over crossways, as a general rule, the height of stacks must be no greater than their width or else stability against tip over must be provided for by other appropriate measures.
- ⑦ For goods that are cubic in shape (e.g. crates or bound stacks of sawn timber), a further load unit may be placed in a central position on top of the load.
- ⑧ In addition, for goods that are cubic in shape (e.g. crates or bound stacks of sawn timber), a further load unit may be placed in a central position on top of the load.

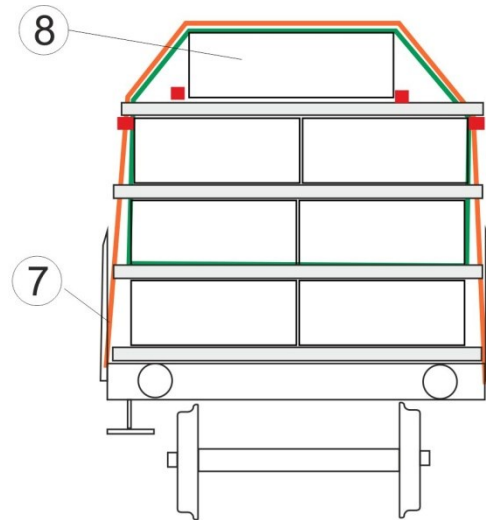
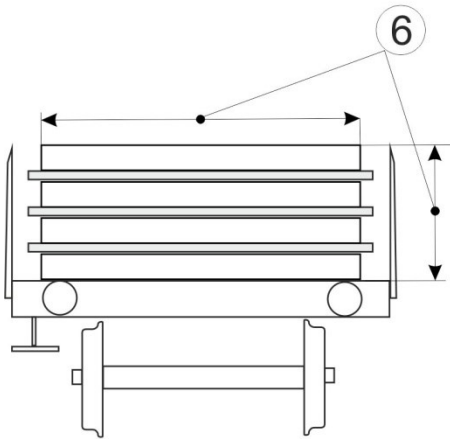

- ⑨ If the load is formed of pipes, the number of tiers must not exceed the number of pipes per tier, one dovetailed tier is permitted at the top of the load.

- ⑩ Where pipes are loaded in dovetailed tiers secured by scotches, no more than four tiers may be formed.

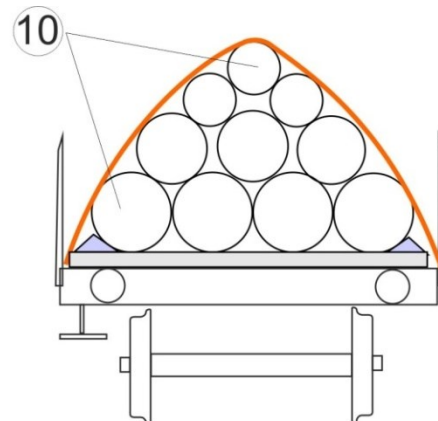
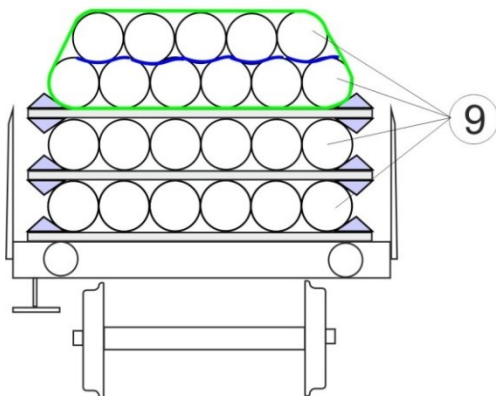

### 5.8.1 Timbers and supporting scotches

Timbers and supporting scotches must be made of suitable material and have an appropriate cross-section. They must generally be of a single piece and cover the full width of the load unit or the load. They must not be able to tip or roll. Hence timbers and supporting scotches laid crosswise in the wagon must be rectangular in cross-section and rest on their broader face.

The following are acceptable:

- **for bearing purposes** (e.g. intermediate timbers for tiers of steel pipes): edge-sawn timber or planks as defined in standard EN 338, strength class C 24, sharp-edged, with thickness of at least 6 cm and a minimum cross-section according to the use in question,
- **for separation purposes** (e.g. intermediate timbers for continuous cast slabs): boards or battens, thickness<sup>1)</sup> according to use from approx. 2 cm upwards, at least 5 cm for single-piece timbers and supporting scotches that are to accommodate nailed scotches.

The number of timbers and supporting scotches to be used will depend on the mass, length, vibration characteristics, and nature of the goods.

For goods that are not liable to sag, use:

- ① two timbers **or**
- ② **pairs** of timbers side-by-side (2x2) for extra-long or -heavy loads.

For flexible goods, use at least four timbers, spread evenly along the load.

For the loading of rails, the number of timbers and supporting scotches shall depend on the mass, length, consistency and means of loading of the rails.

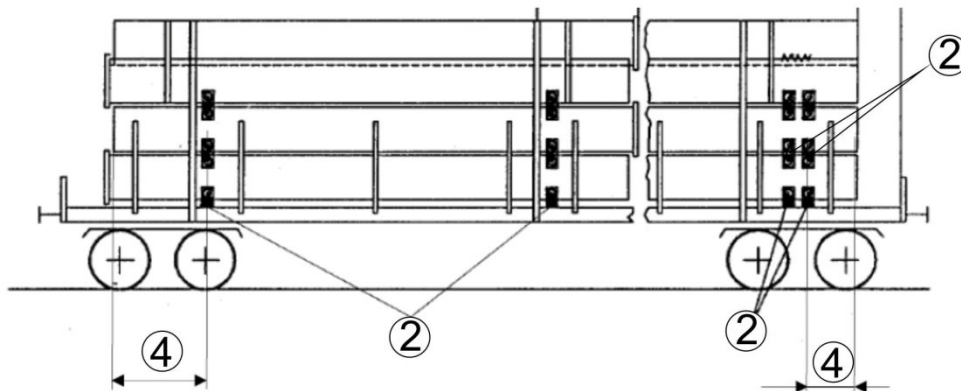

- ③ Timbers and supporting scotches that are placed across the wagon and are liable to slide, for example during the loading of rails or steel profiles in several layers, must be secured against movement. To prevent them from hitting the stanchions in the event of longitudinal movement of the goods, timbers and supporting scotches should be placed approximately half-way between adjacent sets of stanchions.

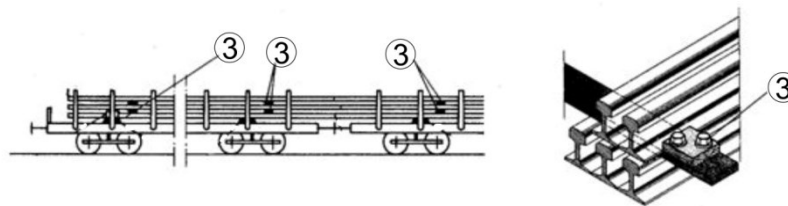

- ④ The load protrudes past the timbers and supporting scotches by at least:

50 cm		30 cm
for goods with a rough surface:		
30 cm		20 cm

<sup>1)</sup> If exceptionally several pieces have to be placed one on top of another to obtain the desired thickness, the pieces must be firmly joined using nails, screws, etc.

## 5.8.2 Binding of goods in load units

Stacked loads must be bound together in load units using straps or steel strips (breaking strength depending on nature of goods from 1400 daN<sup>1)</sup> up to 4000 daN).

The straps used for indirect fastenings and bindings for load units may be twisted upon tensioning. The total twist on each strap may equal three twists of 360°.

The twist may also be located in those parts of the strap resting on the load, e.g. on the curve of a pile of logs, or over a dovetailed stack of tubing. No twisting of the strap is permitted in edged areas, e.g. packages of sawn timber, girders, wagon sides, etc.

Goods that lie above the stanchions should be bound together with goods that are secured by the stanchions, if no other form of securing is possible.

The number of bindings to be arranged evenly depends on the mass, length, vibration characteristics, and nature of the goods. Each stack must have at least two bindings (see paragraph 1.5).

- ① When stacks formed of cylindrical units are secured by scotches and protrude above the stanchions by more than half their diameter, bindings for load units must always be provided as an additional means of securing.

Cylindrical load units forming a dovetailed tier should be bound to the supporting tier.

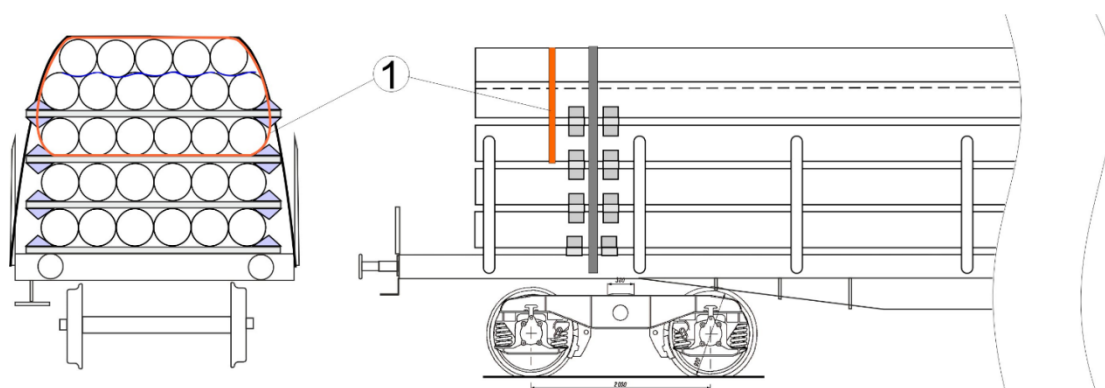

- ② Where timbers are bound up with the load and laid across the wagon, the bindings should be made in a groove.

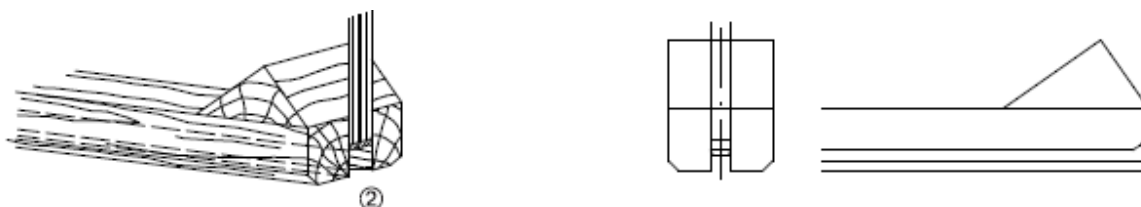

- ③ The use of steel strips for binding in load units, stacked packages of square-sawn timber, wooden boards and edge-sawn timber (formation of stacks) is not permitted due to the particular risk of accident posed by the potential tearing of the strips.

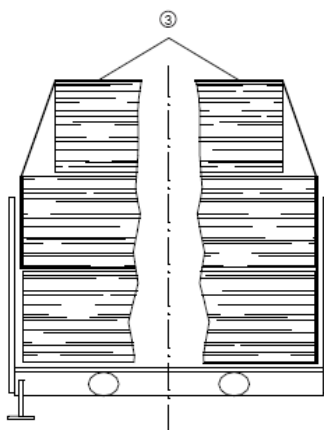

<sup>1)</sup> For low-density goods such as sawn timber, bindings with a breaking strength of 700 daN are permitted on an exceptional basis.

### 5.8.3 Securing

Stacks must be secured like individual objects both lengthways and crosswise in the wagon against movement, rolling off the wagon and tipping.

Depending on the type of goods, the provisions in paragraphs 5.4, 5.5, 5.6 and 5.7 should be complied with.

#### Additional indications:

Where use is made of nailed timbers, guide-pieces or scotches, the load mass to consider when calculating the number of nails is as follows:

- for units stacked in tiers, the mass per tier, plus, as appropriate, the mass of one dovetailed tier,
  - for dovetailed stacks, the mass of the whole stack.
- ① Where load units arranged in tiers are to be secured against lateral movement, scotches should be fixed to the ends of the timbers to prevent their movement, not least in relation to the underlying tier. For this reason, the scotches must be attached to both the top and the bottom of the timber.

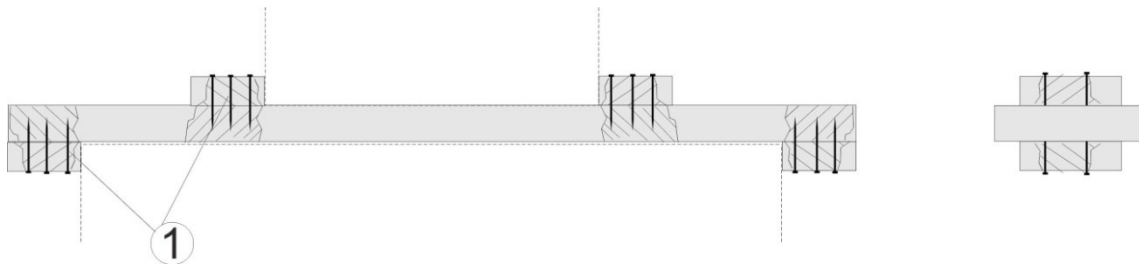

- ② When attaching scotches used for cylindrical goods (for example steel pipes), the scotches must be the same width as the timbers to provide sufficient width for nailing and to prevent the scotches from splitting. Scotches should be nailed from both inside and outside, to this end, the securing devices should be prepared prior to loading.

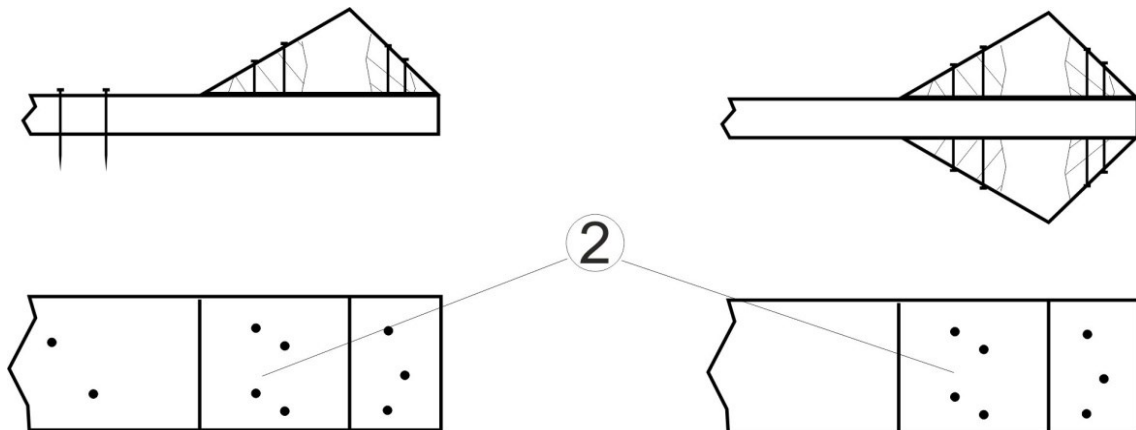

For heavy cylindrical goods (e.g. steel pipes) that extend above the stanchions by more than half their diameter,

- ③ the scotches must also be secured on both sides by steel connecting plates
  - above the stanchions if the load is arranged in flat tiers,
  - on the underlying timbers if the load is dovetailed.

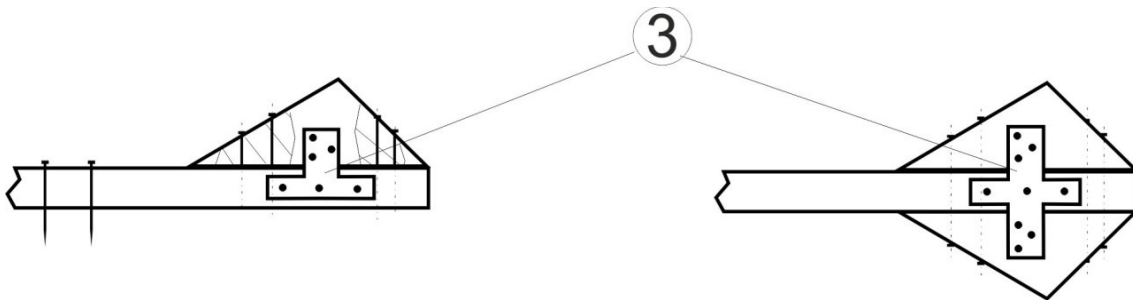

- ④ To make the indirect fastenings more effective, the upper profile of dovetailed stacks of cylindrical goods should be rounded. The height ( $h$ ) of the rounded section should be at least 20 cm and no more than  $\frac{1}{3}$  of the width ( $l$ ) of the load. Exceptions from this rule are permitted for pipes loaded in flat tiers with a single dovetailed tier

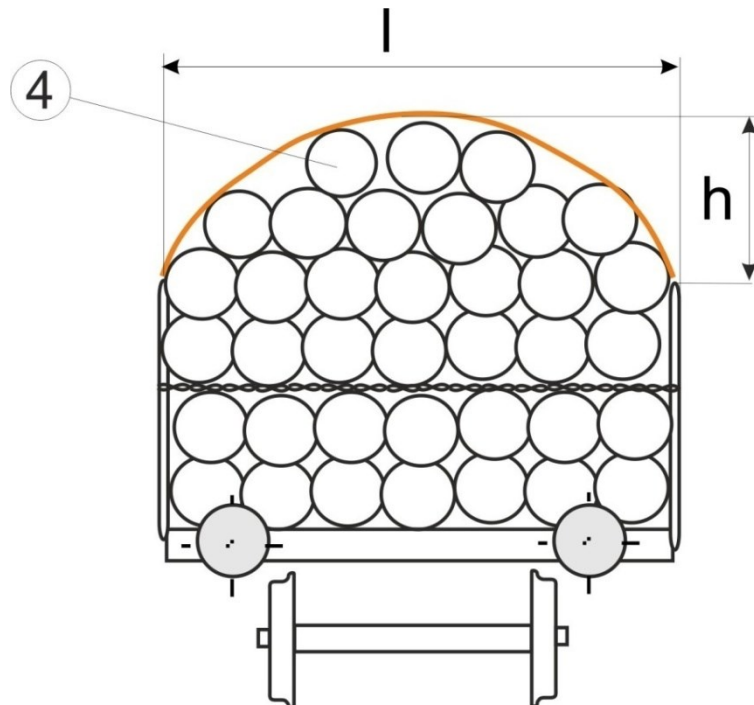



## 5.9 Goods loaded on several wagons

When goods are loaded on several wagons, a distinction should be made between:

- rigid units (e.g. concrete beams) and
- flexible units<sup>1)</sup> (e.g. rails, steel rods for concrete, plastic pipes).

### 5.9.1 Rigid units

must be loaded on two bogie wagons with swivelling/sliding-swivelling bolsters. They must be transported as exceptional consignments (see paragraph 7 too).

The goods (long goods, self-supporting goods) should be loaded on two flat bogie wagons of the same type by using a swivelling bolster, a sliding-swivelling bolster and, if necessary, an intermediate and/or guard wagon. If necessary, the wagon sides and stanchions must be folded down.

The goods should be fixed to the wagon by means of the swivelling bolster. In addition, the sliding-swivelling bolster enables the necessary longitudinal compensation between the goods and the wagon when negotiating curves as well as the longitudinal movement of the buffing and draw gear. In case of an off-centre load, the maximum permitted load of the wagon (force application points) must be demonstrated through calculations or tests.

The swivelling/sliding-swivelling bolsters must, as far as possible, be placed in a central position within  $\pm 1$  m of the longitudinal axis of the vehicle and must be secured sufficiently to withstand stresses likely to occur during transit.

Concerning vibrations, the distance  $n_i/n_a$  is optimal at a ratio of 2.67:1. In principle this distance should be observed during loading.

The load must project above the swivelling bolsters by at least 1 m. For other load units (e.g. concrete sleepers), exemptions are granted when the contact points required by the design must be observed. In these cases, the necessary measures must be taken to ensure the load unit cannot slide beyond the swivelling bolsters.

If so required by the shape of the goods, the swivelling/sliding-swivelling bolsters may be fitted with an additional device for the purpose of additional securing.

On straight track the centre of gravity of the load must be located between the swivelling/sliding-swivelling bolsters and above the longitudinal axis of the wagon.

### Operating conditions

These consignments may not be subject to hump or fly shunting, nor may they collide with other vehicles that have been fly or hump shunted.

The transport units must be coupled in such a way that the buffers are in slight contact.

Trains including these transport units may not be pushed.

If the brake of a wagon forming part of a transport unit has to be isolated, the brakes on other wagons (carrier wagons, intermediate wagons and guard wagons) also have to be isolated.

### 5.9.2 Flexible units

may be loaded on several wagons with collapsible end boards or stanchions. On certain railways, units loaded on more than two wagons can be transported in block trains as standard consignments (see paragraph 7).

When loading flexible units:

- a vertical clearance of at least 50 mm must be left between the load and the folded end boards and/or the buffer heads
- the maximum load should be no more than
  - 75% for axle wagons
  - 85% for bogie wagons

of the applicable load limit for the wagon and for the line the train is running on.

---

<sup>1)</sup> A load is considered flexible if it can safely negotiate curves with a minimum radius  $R$  of 75 m.

For the distribution of the load, the provisions of paragraph 3 should be observed.

- ① Flexible units bound into bundles (steel rods for concrete and similar goods) must not be loaded in more than four tiers, with a clearance of approx. 10 cm between the load units and the wagon sides or stanchions, to allow the load to settle.

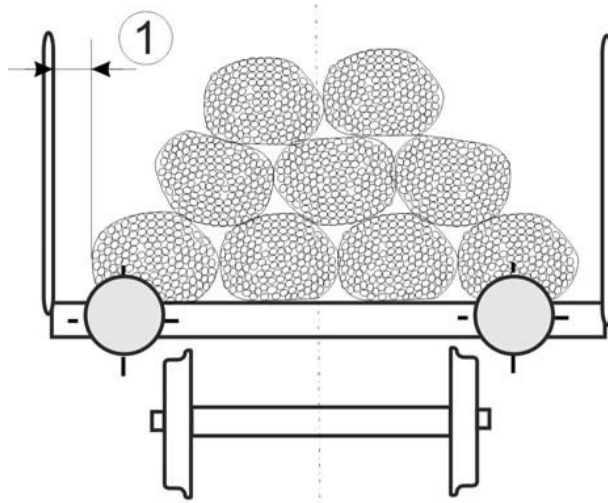

The load must

- be bound together with straps (breaking strength: 4000 daN) or with wire ( $\varnothing$  8 mm) between the wagons and, on wagons fitted only with stanchions, bound approx. 1 m from the ends of the load,
- be at least 50 cm clear of the ends of the loading surface,
- project by approx. 1 m over the timbers at the ends.

Flexible load units that are not bound into bundles (rails and similar goods) must be loaded

- to a maximum of 4 tiers when up to 36 m in length and
- to a maximum of 3 tiers when longer than 36 m.

The load units should be secured, e.g. using spacers at a distance of 1.5 to 3 m from the ends of the load.

- ② The spacers must be designed so as to maintain a clearance of approx. 10 cm from the wagon sides or stanchions. In addition, they must be firmly fixed to the stanchions.
- ③ Their lower edges must be at least 5 cm lower than the bearing level below the bottom tier of rails.

If timbers are used, they should be secured against movement as shown in paragraph 5.8.1.

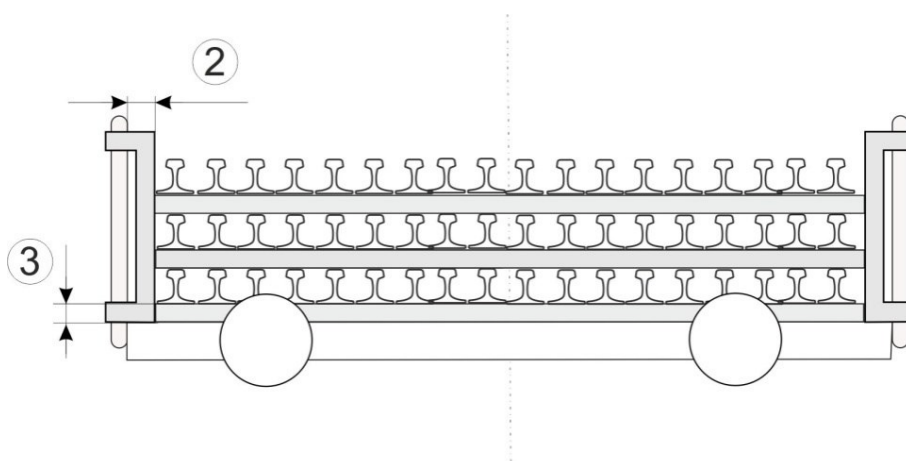

If the upper tier is not completely filled, it can be secured by means of:

- ⑤ straps tensioned in opposite directions in the vicinity of the spacers (breaking strength at least 4000 daN)  
**or**
- ⑥ at least two wires (Ø 5 mm) in the vicinity of the spacers. The wires must also be secured to the facing stanchions, **or**
- ⑦ scotches nailed or screwed at the middle of the load to all the timbers and secured by at least two fastenings (minimum breaking strength: 700 daN, straight pull).

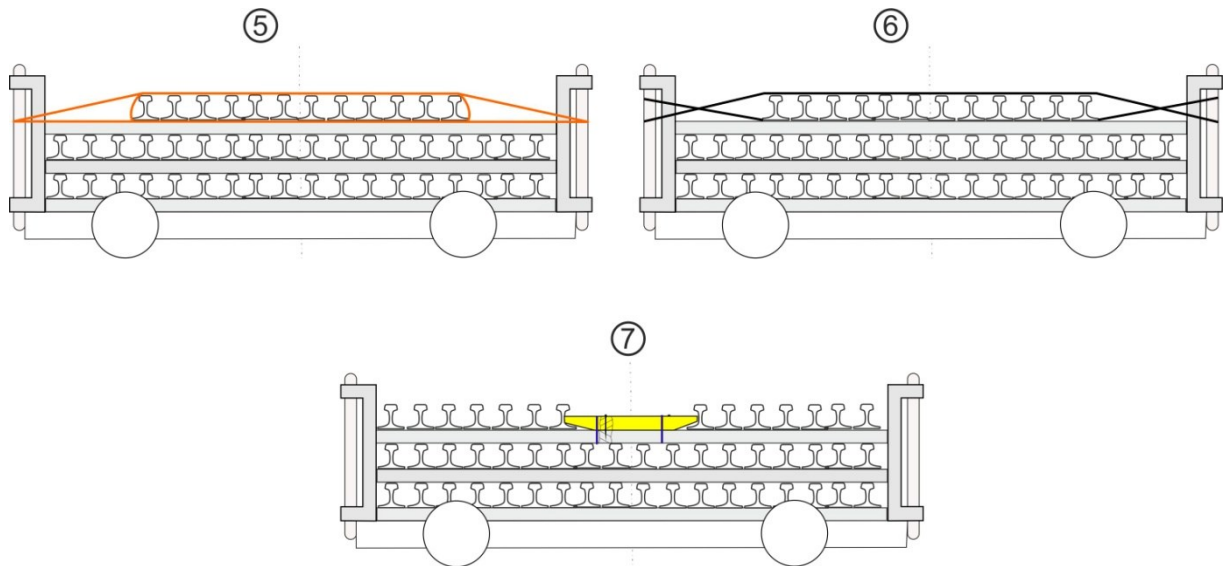

Clearances:

- depending on its length, the load must respect the following clearances from the ends of the loading surface on the end wagons:

Length of units	Minimum clearances
up to 36 m	50 cm
> 36 m up to 60 m	75 cm
> 60 m up to 90 m	100 cm
> 90 m up to 120 m	125 cm
> 120 m up to 180 m	150 cm

- and must project beyond the timbers at its ends by:
  - at least 100 cm for loads up to 36 m in length,
  - at least 150 cm for loads longer than 36 m.
  - at least 200 cm for loads longer than 150 m.

In view of the longitudinal movement that may occur during transit, movement in the clearance is permitted, provided that the load projects sufficiently beyond the final end timber on the facing side, i.e. by:

- at least 50 cm for rail lengths of up to 60 m
- at least 75 cm for rail lengths of more than 60 m

while complying with the rules set out in paragraph 4.2



## 6 Covering of loads

### Goods should be covered:

- in compliance with the version of the RID in force and the tariffs and customs regulations applicable,
- for protection against the weather,
- to avoid them being blown away by the wind.

### 6.1 Covering with sheets/single-use sheets

#### 6.1.1 Sheets should be made as per UIC Leaflet 806

- of coated woven fabric,
- strong and fire-resistant,
- fitted with eyelets for securing purposes.

#### Placing the sheet on the load

- The owner's mark and the number of the wagon and of each sheet must be visible,
- when using the sliding method of loading, the sheets should be fixed directly to the load or to the sled,
- water must be able to run off the sheets, which should not sag (avoid puddles),
- when using several sheets, the ends should overlap by approx. 50 cm,
- when indirect fastenings are used, no metallic bindings should be applied to the sheets.

#### Attaching the sheets

Sheets must be tautly attached using non-metallic bindings (breaking strength approx. 500 daN) to each ring (eyelet) and to the rings and hooks on the wagon with double knots (to fixed wagon parts only), sheets must not be nailed in place,

- ① each binding must be knotted to the closest sheeting ring (eyelet) on the wagon with a double knot,
- ② when using several sheets, each must be attached in the overlap zone using at least 3 oblique bindings on each side of the wagon.
- ③ if an eyelet is missing at the point where the sheets overlap, the third binding may be replaced by a fastening that encircles the whole sheet

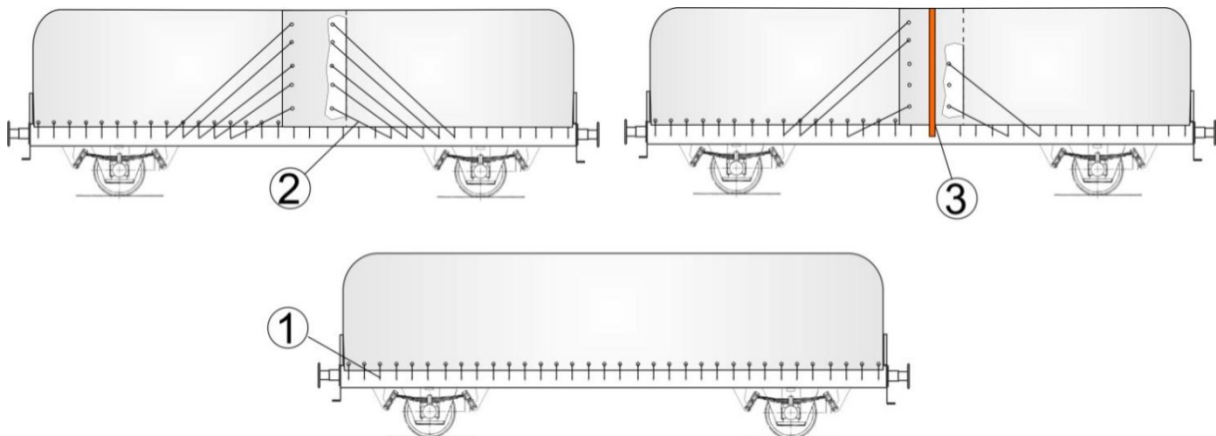

### 6.1.2 Composition and use of single-use sheets

When placing single-use sheets on the load, care should be taken to avoid the formation of puddles and ensure free run-off of water.

Sheets should be protected against any sharp edges on parts of the wagons or loads by corner pieces.

No overlap of single-use sheets is permitted.

If using indirect fastenings, no metallic bindings should be applied to the sheets.

- ④ Single-use sheets must be attached using non-metallic bindings (breaking strength approx. 500 daN) on each eyelet of the sheet, they should be tied to the rings and hooks (on the fixed parts of the wagon only) with double knots, not nailed in place, **and**
- ⑤ must be secured by means of an indirect fastening every 2 m approx.

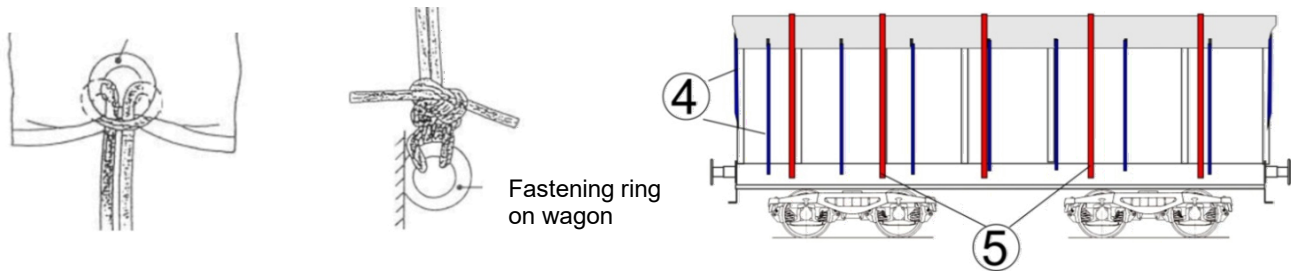

#### Technical specification (minimum requirements)

<b>Material</b>	UV-stabilised PE tape-grade fabric	
	<ul style="list-style-type: none"> <li>- Cut and welded fabric</li> <li>- Triple hem all the way round, stitched four times</li> </ul>	
<b>Manufacture</b>	<ul style="list-style-type: none"> <li>- 20 mm galvanised iron eyelets, every 78 cm approx. on the broad sides and every 100 cm approx. on the long sides</li> <li>- Inscription label on both sides</li> </ul>	
<b>Weight</b>	240 g/m <sup>2</sup>	EN ISO 2286-2
<b>Tear strength (warp/weft)</b>	1'200/1'050 N/5 cm	EN ISO 1421
<b>Elongation at break (warp/weft)</b>	17/24 %	EN ISO 1421
<b>Tear propagation resistance (warp/weft)</b>	230/230 N/5 cm	DIN 53.363
<b>Weld strength</b>	800 N/5 cm	
<b>Weld / fabric (force required to detach weld from fabric)</b>	22 N/5cm	DIN ISO 2411
<b>Eyelets pull-out strength</b>	750 N	EN ISO 1421
<b>Low-temperature resistance</b>	down to -40 °C	
<b>High-temperature resistance</b>	up to +80 °C	
<b>Waterhead</b>	40 cm	EN ISO 20811
<b>Flammability</b>	B2	DIN 4102

#### Observation:

Flammability class B1 is obtained only in white, the other values apply to all colours.

## 6.2 Covering using mesh or netting

### Composition

- Metallic mesh (chicken-wire) with a mesh width of up to 100 mm,
- Nets made of synthetic materials or natural fibres with a mesh width of up to 30 mm<sup>1)</sup>

### Attaching the mesh/netting

- ① The mesh or netting is to be secured at intervals of approx. 2 m, using non-metallic bindings (breaking strength: approx. 50 daN), at each end of the wagon: at least two bindings (these should also be made of wire if using chicken-wire mesh) or secured as per ④.
- ② All the bindings are to be tied to the net itself **or**
- ③ are stretched tight crossways over the net **or**
- ④ the net is stretched tight and attached tautly to the wagon hook (hooks are present on e.g. Eaos wagons).

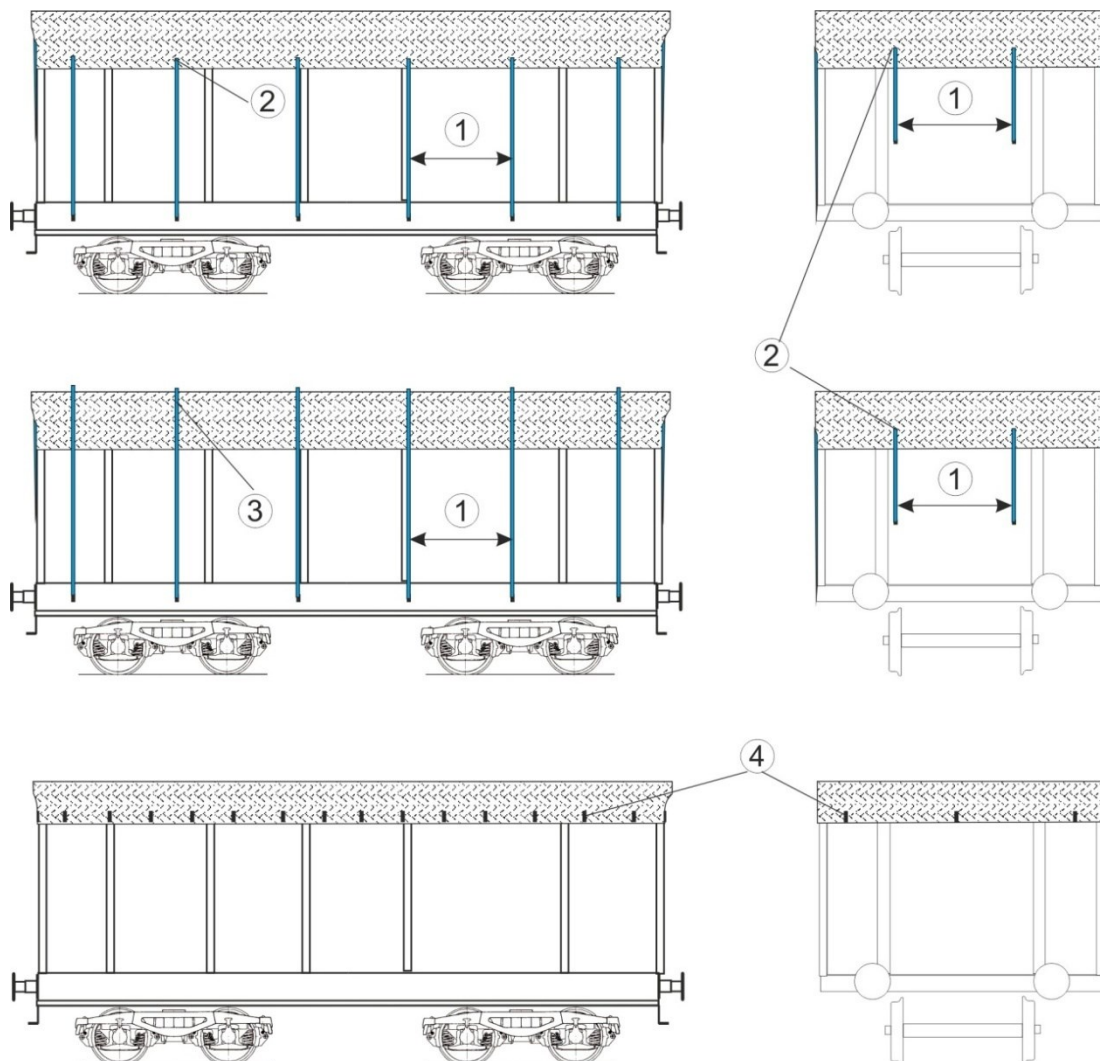

<sup>1)</sup> Longitudinal breaking strength at least 39 daN, transverse breaking strength at least 48 daN (test specimen 10 cm wide, 3 threads)





## 7 Exceptional consignments

A consignment is considered an exceptional consignment when it occasions particular difficulties for the fixed installations or the wagons of one of the railways/RUs used as a result of its outer dimensions, its mass or its nature and can therefore only be forwarded subject to specific technical or operational conditions.

In particular, the following consignments must be considered exceptional:

- loads which are not secured in accordance with volumes 1 or 2 of the Loading Guidelines and for which there are no equivalent alternative securing arrangements, e.g. in accordance with information sheets published on pink or yellow paper (see paragraph 1.2),
- loads which, as a result of the width restrictions imposed, encroach the loading gauge prescribed under paragraph 4.1 for the line in question,
- rigid load units carried on two or more wagons with swivelling/sliding-swivelling bolsters (see paragraph 5.9.1),
  - flexible units loaded on more than two wagons (see paragraph 5.9.2) <sup>1)</sup>, see<sup>2)</sup>
- units that must be transhipped in order to be forwarded to the destination station when they weigh over 25 t and/or are carried on low-loader wagons (only applicable in case of transhipment on railways with different gauges),
- consignments to be transhipped to a ferry if they do not meet the regulations of GCU<sup>3)</sup>, Appendix 14,
- Railway vehicles, loaded on their own wheels, which are themselves the subject of a freight contract if they bear neither the RIV or RIC marking, the TEN marking (valid in EU Member States) or the derogation plate in accordance with GCU Appendix 11, Point 2.1 or 2.2
- Wagons with more than 3 axles per bogie, if loaded
- vehicles whose loads exceed the permissible load limit of the lines used,
- vehicles loaded in excess of the maximum load limit indicated (load limit box / additional box), up to the maximum bearing capacity allowed by their design,
- vehicles without an indicated payload, e.g. construction vehicles,
- vehicles loaded without indication of the load limits,
- vehicles running on their own wheels with technical specificities (motive power units, multiple units, tram vehicles, construction vehicles) whose carriage requires specific operating measures.

**Exceptional consignments may only be accepted under the special conditions agreed on beforehand between RUs/IMs/railways.**

<sup>1)</sup> NB: On certain railways such consignments are moved taking into account the loading examples provided in the UIC Loading Guidelines:

- For block trains: SZDC (CZ), DB, SBB, ZSR (SK), ProRail (NL), MAV, CFL
- For wagonload traffic: DB, SBB
- Loaded on three wagons of max. length 36m: RFI (FS);

<sup>2)</sup> For BDZ, EWS, GySEV, FS, HZ, MZ, ZFBH, ZRS, ZS, ÖBB, PKP, ADIF, ASTOC, SNCB, SNCF, SZ and TCDD, load units loaded on more than two wagons are considered exceptional consignments, even when forwarded in block trains.

<sup>3)</sup> General Contract of Use for wagons



## 8 Table 1: List of the loading gauges

### List of loading gauges

Name of Railway Undertaking	Abbreviation	Country code	Table
International loading gauges			1 <sub>1</sub>
Loading gauge (UIC) GA			1 <sub>2</sub>
Loading gauge (UIC) GB			1 <sub>3</sub>
Finnish Railways	VR	10	1 <sub>2</sub> , 1 <sub>3</sub> , 1 <sub>5</sub>
Lithuanian Railways	LG	24	1 <sub>4</sub>
Albanian Railways	HSB	41	1 <sub>2</sub> , 1 <sub>3</sub> , 1 <sub>4</sub>
Raab-Oedenburg-Ebenfurt-Railway	GySEV	43	1 <sub>2</sub> , 1 <sub>3</sub> , 1 <sub>4</sub>
Srpska Republic Railways	ZRS	44	1 <sub>2</sub> , 1 <sub>3</sub> , 1 <sub>4</sub>
Railways of the Bosnia-Herzegovina Federation	ZFBH	50	1 <sub>2</sub> , 1 <sub>3</sub> , 1 <sub>4</sub>
Polish State Railways	PKP	51	1 <sub>4</sub>
Bulgarian State Railways	BDZ	52	1 <sub>2</sub> , 1 <sub>3</sub> , 1 <sub>4</sub>
Romanian Railways	CFR	53	1 <sub>4</sub>
Grup feroviar roman	RO-GFR	53	1 <sub>4</sub>
Servtrans Invest	RO STI	53	1 <sub>4</sub>
Czech Cargo Railways (formerly CD)	CDC	54	1 <sub>2</sub> , 1 <sub>3</sub> , 1 <sub>4</sub>
Rail Cargo Hungaria (formerly MAV)	RCH	55	1 <sub>2</sub> , 1 <sub>3</sub> , 1 <sub>4</sub>
Slovakian Cargo Railway Company S.A (formerly ZSSK)	ZSSKC	56	1 <sub>2</sub> , 1 <sub>3</sub> , 1 <sub>4</sub>
Lötschberg Railways	BLS	63	1 <sub>6</sub>
Nord-Milano Esercizio Railways	FNME	64	1 <sub>2</sub> , 1 <sub>7</sub>
Former Yugoslav Republic of Macedonia Railways	MZ	65	1 <sub>2</sub> , 1 <sub>3</sub> , 1 <sub>4</sub>
Ahaus-Alstätter Railways	AAE	68	1 <sub>2</sub> , 1 <sub>4</sub>
English, Welsh and Scottish Railway International	EWS	70	1 <sub>8</sub>
Spanish State Railways	RENFE	71	1 <sub>2</sub> , 1 <sub>9</sub>
Serbian Railways (formerly JZ)	ZS	72	1 <sub>2</sub> , 1 <sub>3</sub> , 1 <sub>4</sub>
Hellenic Railways (formerly CH)	TRAINOSE	73	1 <sub>2</sub> , 1 <sub>3</sub> , 1 <sub>4</sub>
TRAFIKVERKET (Sweden)	TRV	74	1 <sub>2</sub> , 1 <sub>3</sub> , 1 <sub>10</sub>
Turkish Republic State Railways	TCDD	75	1 <sub>4</sub> , 1 <sub>12</sub> , 1 <sub>13</sub> , 1 <sub>14</sub>
Cargonet	C	76	1 <sub>2</sub> , 1 <sub>3</sub> , 1 <sub>15</sub>
Croatian Railways	HZ	78	1 <sub>2</sub> , 1 <sub>3</sub> , 1 <sub>4</sub>
Slovenian Railways	SZ	79	1 <sub>2</sub> , 1 <sub>3</sub> , 1 <sub>4</sub>
DB Schenker Rail	DB	80	1 <sub>2</sub> , 1 <sub>4</sub>
Rail Cargo Austria	ÖBB	81	1 <sub>2</sub> , 1 <sub>4</sub>
Luxembourg Railways	CFL	82	1 <sub>2</sub> , 1 <sub>3</sub> , 1 <sub>4</sub>
Trenitalia	FS	83	1 <sub>7</sub>
Railion Nederland	NL-RN	84	1 <sub>2</sub> , 1 <sub>4</sub>
Swiss Federal Railways / CFF Cargo	SBB/CFF	85	1 <sub>6</sub>
Railion Danmark	DSB	86	1 <sub>2</sub> , 1 <sub>3</sub> , 1 <sub>4</sub>
French National Railways	SNCF	87	1 <sub>1</sub> , 1 <sub>2</sub> , 1 <sub>3</sub> , 1 <sub>18</sub>
Belgian National Railways / B-Cargo	B	88	1 <sub>2</sub> , 1 <sub>16</sub>
Portuguese Railways	CP	94	1 <sub>2</sub> , 1 <sub>9</sub>
Iranian State Railways	RAI	96	1 <sub>17</sub>
Syrian Railways	CFS	97	1 <sub>2</sub> , 1 <sub>3</sub> , 1 <sub>4</sub>
Iraqi Railways	IRR	99	1 <sub>4</sub>



### 8.1 Table 1<sub>1</sub> International loading gauge

For **all lines** except the lines in

- Great Britain (table 1<sub>8</sub>),
- Iran (table 1<sub>17</sub>).

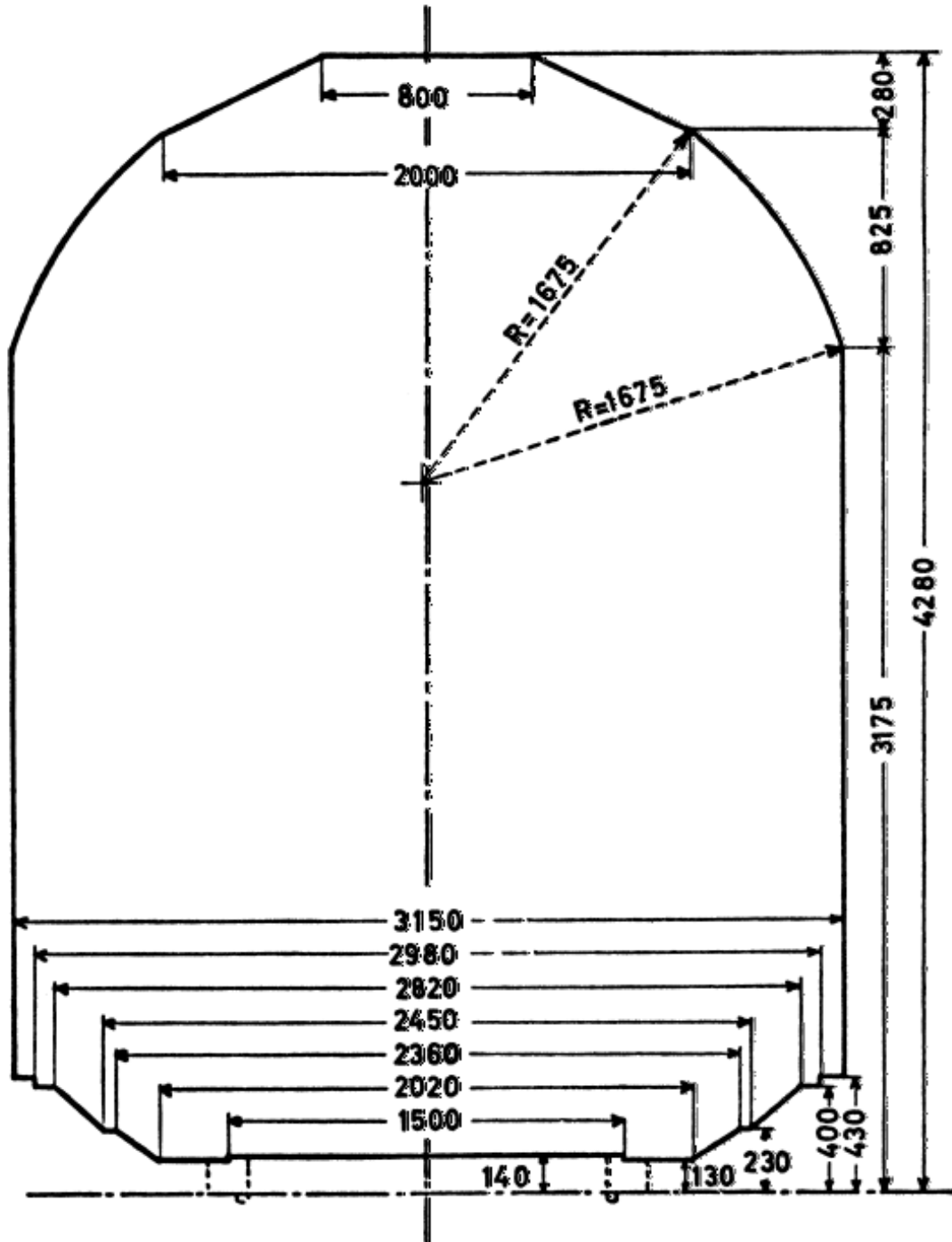

## Half-widths of the gauge

Height above rail level mm	Corresponding half-width mm	Height above rail level mm	Corresponding half-width mm	Height above rail level mm	Corresponding half-width mm	Height above rail level mm	Corresponding half-width mm
		3 450	1 461	3 750	1 260	4 050	893
430		460	1 456	760	1 252	060	871
3 175	1 575	470	1 450	770	1 243	070	850
180	1 573	480	1 445	780	1 234	080	829
190	1 570	490	1 439	790	1 226	090	807
3 200	1 567	3 500	1 434	3 800	1 217	4 100	786
210	1 563	510	1 428	810	1 207	110	764
220	1 560	520	1 422	820	1 198	120	743
230	1 557	530	1 416	830	1 189	130	721
240	1 553	540	1 410	840	1 179	140	700
3 250	1 549	3 550	1 404	3 850	1 169	4 150	679
260	1 546	560	1 398	860	1 159	160	657
270	1 542	570	1 392	870	1 149	170	636
280	1 538	580	1 385	880	1 139	180	614
290	1 534	590	1 379	890	1 128	190	593
3 300	1 530	3 600	1 372	3 900	1 118	4 200	571
310	1 526	610	1 366	910	1 107	210	550
320	1 522	620	1 359	920	1 096	220	529
330	1 518	630	1 352	930	1 085	230	507
340	1 513	640	1 345	940	1 073	240	486
3 350	1 509	3 650	1 338	3 950	1 062	4 250	464
360	1 505	660	1 331	960	1 050	260	443
370	1 500	670	1 323	970	1 038	270	421
380	1 495	680	1 316	980	1 025	4 280	400
390	1 491	690	1 308	990	1 013		
3 400	1 486	3 700	1 301	4 000	1 000		
410	1 481	710	1 293	010	979		
420	1 476	720	1 285	020	957		
430	1 471	730	1 277	030	936		
440	1 466	740	1 269	040	914		
3 450	1 461	3 750	1 260	4 050	893		

## 8.2 Table 1<sub>2</sub>: Loading gauge (UIC) GA

For a list of Railway Undertakings accepting this gauge, see pages T1<sub>2</sub>-3 to T1<sub>2</sub>-5

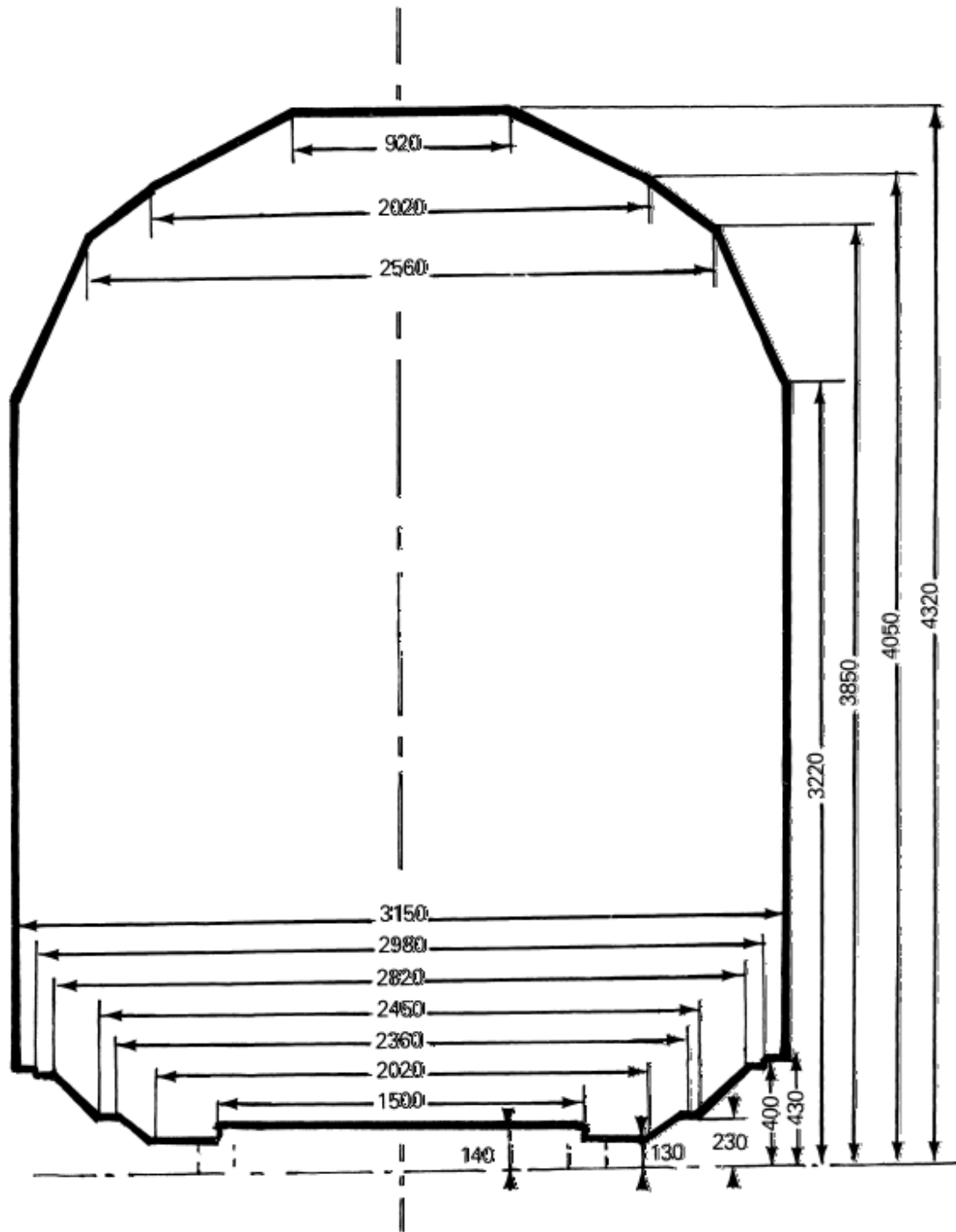

## Half-widths of the gauge

Height above rail level mm	Corresponding half-width mm	Height above rail level mm	Corresponding half-width mm	Height above rail level mm	Corresponding half-width mm	Height above rail level mm	Corresponding half-width mm
		3 450	1 467	3 750	1 326	4 050	1 010
430	1 575	460	1 462	760	1 322	060	989
		470	1 457	770	1 317	070	969
		480	1 453	780	1 312	080	948
		490	1 448	790	1 308	090	928
		3 500	1 443	3 800	1 303	4 100	908
3 220	1 570	510	1 439	810	1 298	110	887
		520	1 434	820	1 294	120	867
230		530	1 429	830	1 289	130	847
240		540	1 425	840	1 284	140	826
3 250	1 560	3 550	1 420	3 850	1 280	4 150	806
260	1 556	560	1 415	860	1 266	160	785
270	1 551	570	1 411	870	1 253	170	765
280	1 546	580	1 406	880	1 239	180	745
290	1 542	590	1 401	890	1 224	190	724
3 300	1 537	3 600	1 397	3 900	1 212	4 200	704
310	1 532	610	1 392	910	1 199	210	684
320	1 528	620	1 387	920	1 185	220	663
330	1 523	630	1 383	930	1 172	230	643
340	1 518	640	1 378	940	1 158	240	622
3 350	1 514	3 650	1 373	3 950	1 145	4 250	602
360	1 509	660	1 368	960	1 131	260	582
370	1 504	670	1 364	970	1 118	270	561
380	1 500	680	1 359	980	1 104	280	541
390	1 495	690	1 354	990	1 091	290	521
3 400	1 490	3 700	1 350	4 000	1 077	4 300	500
410	1 485	710	1 345	010	1 064	310	480
420	1 481	720	1 340	020	1 050	4 320	460
430	1 476	730	1 336	030	1 037		
440	1 471	740	1 331	040	1 023		
3 450	1 467	3 750	1 326	4 050	1 010		



## List of Railway Undertakings accepting the (UIC) GA loading gauge

### **VR**

Transit lines: all  
Stations: all

### **HSH**

Stations: all

### **GySEV**

Transit lines: all  
Stations: all

### **ZRS**

Transit lines: all

### **ZFBH**

Transit lines: all  
Stations: all

### **BDZ**

Transit lines: all  
Stations: all

### **CD**

Transit lines: all  
Stations: all

### **MAV**

Transit lines: all  
Stations: all

### **ZSSK (ZSR)**

Transit lines: all  
Stations: all

### **FNME**

Transit lines: all  
Stations: all

### **MZ**

Transit lines: all  
Stations: all

### **AAE**

Transit lines: all  
Stations: all

### **RENFE**

Transit lines: all  
Stations: all

### **JŽ**

Transit lines: all  
Stations: all

### **CH**

Transit lines: all  
Stations: all

### **TRAFIKVERKET (Sweden)**

Transit lines: all  
Stations: all

### **C (NSB)**

Transit lines: all  
Stations: all

### **HZ**

Transit lines: all  
Stations: all

### **SZ**

Transit lines: all  
Stations: all

### **DB**

Transit lines: all  
Stations: all

### **ÖBB**

Transit lines: all  
Stations: all

### **CFL**

Transit lines: all  
Stations: all

### **NS**

Transit lines: all  
Stations: all

### **DSB**

Transit lines: all  
Stations: all

**SNCF**

Transit lines: all

Station: all, with the exception of the following stations:

AMPLEPUI, AUREC, BAS-MONISTROL, BASTIDE-ST-LAURENT(LA), BEGAAR, BEL-AIR-LA-MEDE, BILLOM, BOENS, BRIVES-CHARENSAC, CABANNES, CANDALE, CAPDENAC, CHALON-SUR-SAONE (PORT NORD), CHAMALIERES-SUR-LOIRE, CHAMBONFEUGEROLLES (LE), CHARBONNIERES-LES-VARENNE, CHATEAUNEUF-LES-MARTIGUES, CHATEAURENARD-DE-PROVENCE, CLAVAU (LES), COLOMBIERS-RD, COURZIEU-BRUSSIEU, DECINES, DEVILLE-LES-ROUEN, DRAP-CANTARON, FIRMINY, FONTVIEILLE, FRAISSE-UNIEUX, GRAND-COMBE-LA-PISE, LANGEAC, LANGOGNE, LESGOR, LIPOSTHEY, LYON-EST, MACON (PORT FLUVIAL), MALBOSC, MAURS, MESSEMPRE, MILLERY-MONTAGNY, NOIRETABLE, NOVES, OYONNAX, PLAN-D'ORGON, PUYEN-VELAY (LE), RICAMARIE (LA), RIOUPEYROUX, SAINT-AMBROIX, SAINT-ANDIOL, TAMARIS, TARTAS, VIERZY, VIF, VILLEURBANNE, VILLEURBANNE-GARAGE, VIZILLE-TERRASSE, YCHOUX.

The loading gauge given in Table 1<sub>1</sub> is applicable for these stations.

**SNCB**

Transit lines: all

Stations: all, with the exception of the following stations:

BEIGNEE, BERZEE, COUR-SUR-HEURE, COUVIN, HAM-SUR-HEURE, JAMIOULX, MARIEMBOURG, PHILIPPEVILLE, PRY, WALCOURT and YVES-GOMEZÉE.

The loading gauge given in Table 1<sub>1</sub> is applicable for these stations.

**CP**

Stations: all

**CFS**

Transit lines: all

Stations: all

### 8.3 Table 1<sub>3</sub>: Loading gauge (UIC) GB

For a list of Railway Undertakings accepting this gauge, see pages T1<sub>3</sub>-3 to T1<sub>3</sub>-5

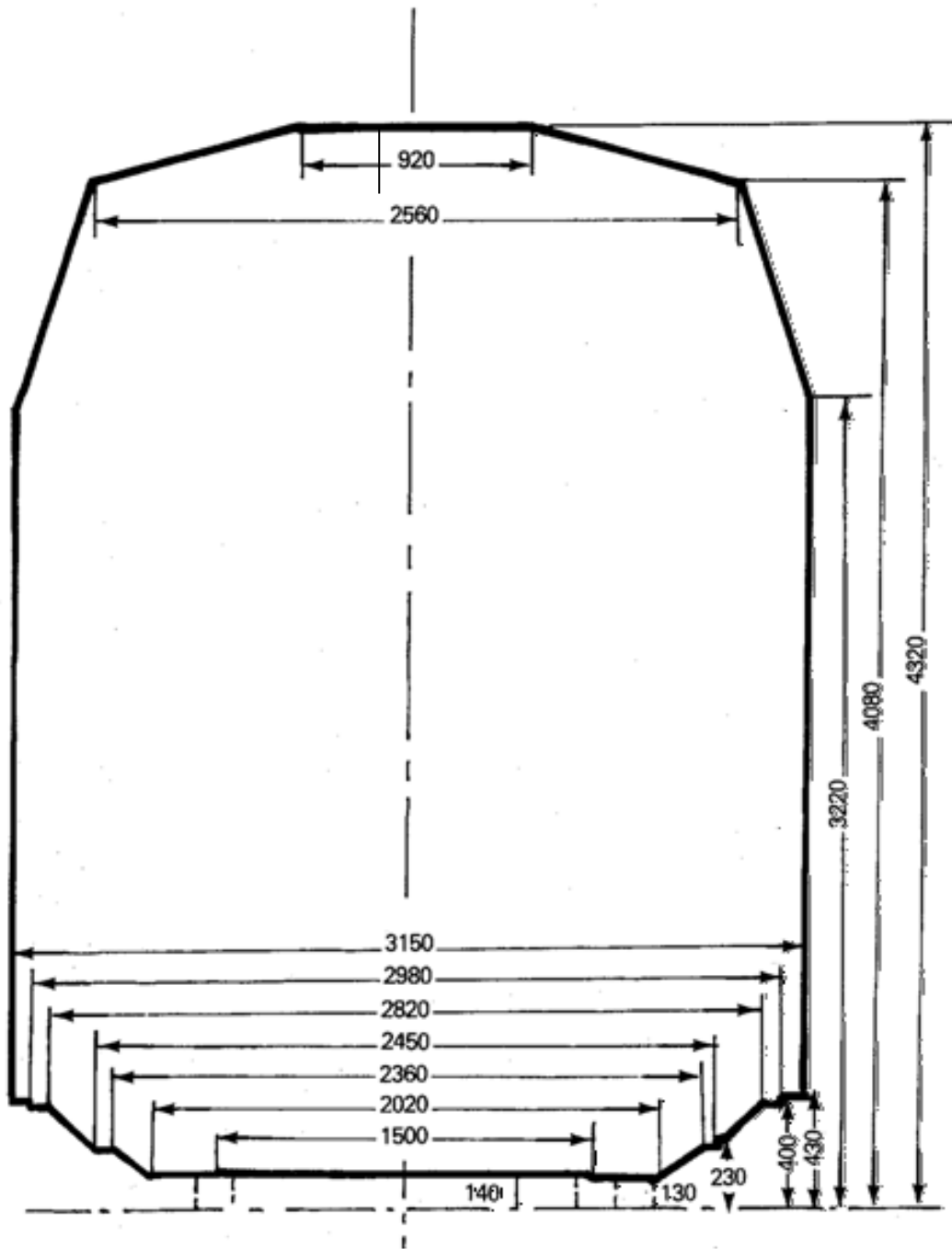

## Half-widths of the gauge

Height above rail level mm	Corresponding half-width mm	Height above rail level mm	Corresponding half-width mm	Height above rail level mm	Corresponding half-width mm	Height above rail level mm	Corresponding half-width mm
		3 450	1 496	3 750	1 393	4 050	1 290
430	1 575	460	1 492	760	1 389	060	1 286
		470	1 489	770	1 386	070	1 283
		480	1 485	780	1 382	080	1 280
		490	1 482	790	1 379	090	1 245
		3 500	1 478	3 800	1 376	4 100	1 211
3 220	1 571	510	1 475	810	1 372	110	1 177
		520	1 472	820	1 369	120	1 143
		530	1 468	830	1365	130	1 109
		540	1 465	840	1362	140	1 075
3 250	1 564	3 550	1 461	3 850	1 358	4 150	1 040
260	1561	560	1 458	860	1355	160	1 006
270	1 557	570	1 454	870	1 352	170	972
280	1 554	580	1 451	880	1 348	180	938
290	1 550	590	1 448	890	1 345	190	904
3 300	1 547	3 600	1 444	3 900	1 341	4 200	870
310	1 544	610	1 441	910	1 338	210	835
320	1 540	620	1 437	920	1 334	220	801
330	1 537	630	1 434	930	1 331	230	767
340	1 533	640	1 430	940	1 328	240	733
3 350	1 530	3 650	1 427	3 950	1 325	4 250	699
360	1 526	660	1 424	960	1 321	260	665
370	1 523	670	1 420	970	1 317	270	630
380	1 520	680	1 417	980	1 314	280	596
390	1 516	690	1 413	990	1 310	290	562
3 400	1 513	3 700	1 410	4 000	1 307	4 300	528
410	1 509	710	1 406	010	1 304	310	494
420	1 506	720	1 403	020	1 300	4 320	460
430	1 502	730	1 400	030	1 297		
440	1 499	740	1 396	040	1 293		
3 450	1 496	3 750	1 393	4 050	1 290		

## List of Railway Undertakings accepting the (UIC) GB loading gauge

### **VR, GySEV, ZRS, ZFBH, RCH, MZ, SZ, DSB, CFS, TRAFIKVERKET (Sweden)**

Transit lines: all

Stations: all

### **CDC**

Transit lines: all

Stations: none

### **HSH**

Stations: all

### **BDZ**

Transit lines: all

Stations: all, with the exception of

BOROUGHTITZA, CHICHKOV TZI, DEBELETZ, GABROVO, GUECHEVO, KJUSTENDIL, KOPILOVTZI, KRASETZ, PLATCHKOV TZI, RADEV TZI, RADOUNTZI, RAJDAVITZA, SAMOVODENE, SOKOLOVO, VARBANOVO, VELIKO, TRAPEZITZA, TRIAVNA

### **ZSSKC**

Transit lines: all

Stations: all, with the exception of

BANSKA BELA, BANSKA STIAVNICA, KREMNICA, KREMNICKE BANE

### **ZS**

Transit lines: all, with the exception of:

VALJEVO-KALENIC and GRLICA-DJENERAL JANKOVIC

Stations: all

### **TRAI NOSE**

Transit lines:

IDOMENI-MESSONISSION, IDOMENI-PROMACHON, MESSONISSION-PROMACHON, ORMENION-PITHION

Stations:

Via IDOMENI, MESSONISSION and PROMACHON:

ADENDRON, AGRAS, ALEXANDRIA, ALIKI, AMINTEON, ANCHIALOS MAC., ARMENION, ARNISSA, ASPROS, DOIRANI, DOMOKOS, DOXARAS, EDESSA, EGHINION-KOLINDROS, EPISKOPI, FILADELPHIA, FLORINA, GALIKOS, GHEFIRA, GIRTONI, IDOMENI, KALINDIA, KASTANAS, KASTANOUSSA, KATERINI, KILKIS, KOMANOS, KAZANI, KRANON, LACHA-NOKIPI, LAKIA, LARISSA, LATOMION, LEPTOKARIA, LITOKHORON, MANDRAKION, MAVRODENDRION, MESSONISSION, METALLIKO, MOURIES, NAOUSSA, N. AGATHOU-POLIS, ORFANA, PALEOFARSALOS, PLATAMON, PLATI, POLIKASTRON, PROMACHON, PTOLEMAIS, RAPSANI, RODOPOLIS, SERRE, SIDIROKASTRO, SINDOS, SKIDRA, SKOTOUSSA, STRIMON, TEMPI, THESSALONIKI, VELESTINON, VERIA, VEVI, VIRONIA, VOLOS, XECHASMENI.

Via ORMENION and PITHION:

ALEXANDROUPOLIS, CHIMONION, DIDIMOTICHON, DIKEA, FERE, LAGHINA, LAVARA, N. ORESTIAS, N. VISSA, ORMENION, PEPLOS, PITHION, SOUFLION, TICHERON

**C (NSB)**

Transit lines: all

Stations: all, with the exception of ARENDAL

**HZ**

Transit lines: all

Stations: all, with the exception of

KASTEL STARI, KASTEL SUCURAC, SADINE, SOLIN LUKA, SPLIT, SPLIT PREDGRADE

**CFL**

Transit lines

BETTEMBOURG-KLEINBETTINGEN, WASSERBILLIG-RODANGE/ATHUS

Stations: all, with the exception of

BELLAIN, BISSEN, CLERVAUX, COLMAR-BERG, COLMAR-USINES, CRUCHTEN, DIEKIRCH, DOM  
MELDANGE, DRAUFFELT, ETTTELBRUCK, GOEBELSMUEHLE, KAUTENBACH, LINTGEN,  
LORENTZWEILLER, MAU LUSM UEHLE, MERSCH, MICHELAU, SCHIEREN, TROISVIERGES,  
WALFERDANGE, WILNERWILTZ

**SNCF**

See table 1<sub>18</sub>

8.4 Table 1<sub>4</sub>: Loading gauge accepted by LG, HSH, GySEV, ZRS, ZFBH, PKP, BDZ, CFR, CD, MAV<sup>1)</sup>, ZSSK (ZSR), MZ, AAE, JZ, CH, TCDD<sup>2)</sup>, HZ, SZ, DB, ÖBB, CFL, NS, DSB, CFS, IRR

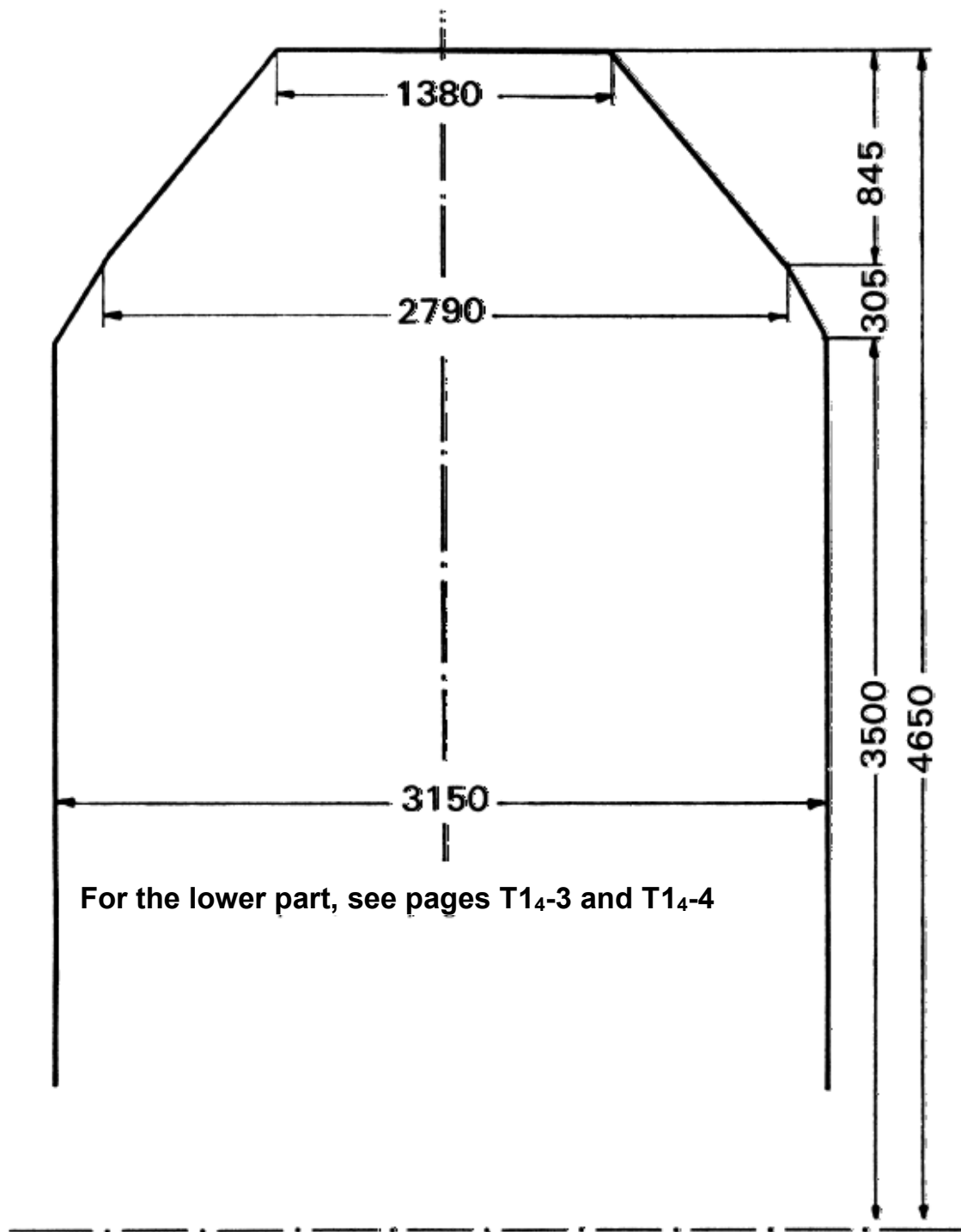

With the exception of following stations:

- 1) **MAV**: BUDAPEST-DELI-PU  
The loading gauge given in Table 11 is applicable for this destination station.
- 2) **TCDD**: KAPIKULE, EDIRNE, ALPULLU, LULEBURGAZ, MURATLI, CORLU, CERKEZKOY, HALKALI, KAPIKOY, VAN  
The loading gauges given in Tables 1<sub>12</sub> or 1<sub>13</sub> or 1<sub>14</sub> are applicable for these destination stations.

Half-widths of the gauge

Height above rail level mm	Corresponding half-width mm	Height above rail level mm	Corresponding half-width mm	Height above rail level mm	Corresponding half-width mm	Height above rail level mm	Corresponding half-width mm
		3 800	1 398	4 100	1 149	4 400	899
430	1 575	805	1395				
3 500							
510	1 569	810	1 391	110	1 141	410	890
520	1 563	820	1 382	120	1 132	420	882
530	1 557	830	1 374	130	1 124	430	874
540	1 551	840	1 366	140	1 116	440	865
3 550	1 545	3 850	1 357	4 150	1 107	4 450	857
560	1 540	860	1 349	160	1 099	460	849
570	1 534	870	1 341	170	1 090	470	840
580	1 528	880	1 332	180	1 082	480	832
590	1 522	890	1 324	190	1 074	490	823
3 600	1 516	3 900	1 316	4 200	1 065	4 500	815
610	1 510	910	1 307	210	1 057	510	807
620	1 504	920	1 299	220	1 049	520	798
630	1 498	930	1 291	230	1 040	530	790
640	1 492	940	1 282	240	1 032	540	782
3 650	1 486	3 950	1 274	4 250	1 024	4 550	773
660	1 481	960	1 266	260	1 015	560	765
670	1 475	970	1 257	270	1 007	570	757
680	1 469	980	1 249	280	999	580	748
690	1 463	990	1 241	290	990	590	740
3 700	1 457	4 000	1 232	4 300	982	4 600	732
710	1 451	010	1 224	310	974	610	723
720	1 445	020	1 216	320	965	620	715
730	1 439	030	1 207	330	957	630	707
740	1 433	040	1 199	340	949	640	698
750	1 427	4 050	1 191	4 350	940	4 650	690
760	1 422	060	1 182	360	932		
770	1 416	070	1 174	370	924		
780	1 410	080	1 166	380	915		
790	1 404	090	1 157	390	907		
3 800	1 398	4 100	1 149	4 400	899		



**Lower part of the loading gauge of Railway Undertakings**

**GySEV, CFR, MAV, ÖBB, CFL, DSB**

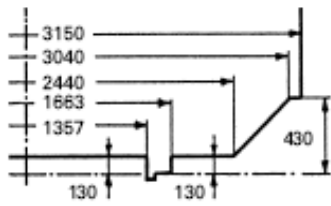

**CH**

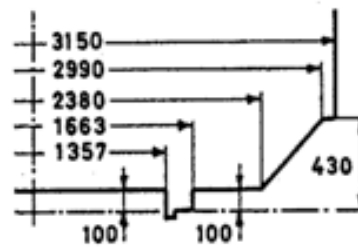

**BDZ, CD, ZSSK (ZSR), AAE, DB**

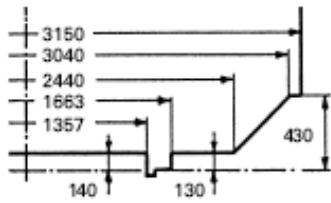

**TCDD**

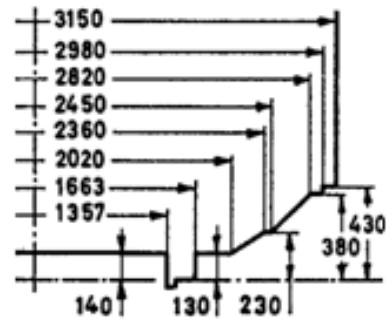

**LG, PKP, NS, IRR**

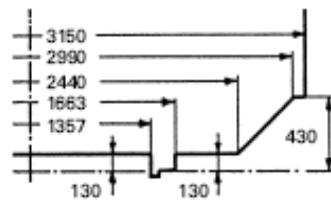

**CFS**

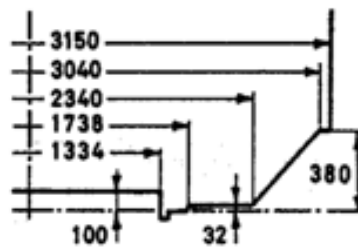

**ZRS, ZFBH, MZ, JZ, HZ, SZ**

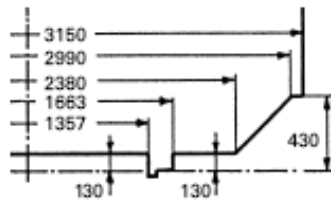

**HSB**

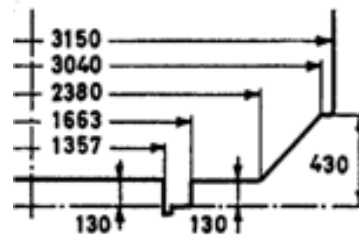



8.5 Table 1<sub>5</sub>: Loading gauge accepted by VR

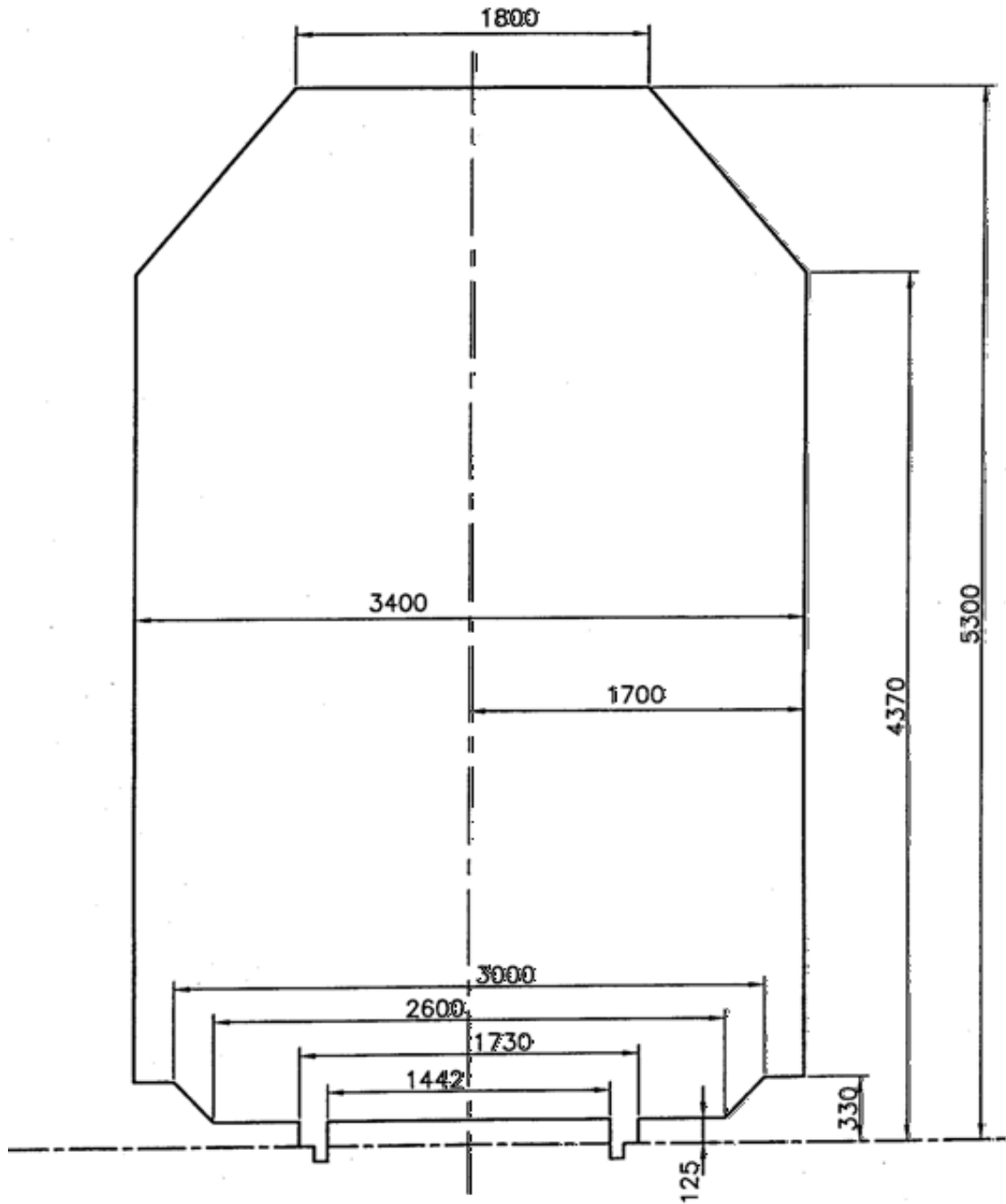

### Half-widths of the gauge

Height above rail level mm	Corresponding half-width mm	Height above rail level mm	Corresponding half-width mm	Height above rail level mm	Corresponding half-width mm
330	1 700				
4 370					
4 380		1 691	-	-	-
4 390		1 683			
4 400	1 674	4 700	1 416	5 000	1 158
410	1 666	710	1 408	010	1 149
420	1 657	720	1 399	020	1 141
430	1 648	730	1 390	030	1 132
440	1 640	740	1 382	040	1 124
4 450	1 631	4 750	1 373	5 050	1 115
460	1 623	760	1 365	060	1 106
470	1 614	770	1 356	070	1 098
480	1 605	780	1 347	080	1 089
490	1 597	790	1 339	090	1 081
4 500	1 588	4 800	1 330	5 100	1 072
510	1 580	810	1 322	110	1 063
520	1 571	820	1 313	120	1 055
530	1 562	830	1 304	130	1 046
540	1 554	840	1 296	140	1 038
4 550	1 545	4 850	1 287	5 150	1 029
560	1 537	860	1 278	160	1 020
570	1 528	870	1 270	170	1 012
580	1 519	880	1 261	180	1 003
590	1 511	890	1 253	190	995
4 600	1 500	4 900	1 244	5 200	986
610	1 494	910	1 235	210	977
620	1 485	920	1 227	220	969
630	1 476	930	1 218	230	960
640	1 468	940	1 210	240	952
4 650	1 459	4 950	1 201	5 250	943
660	1 451	960	1 192	260	934
670	1 442	970	1 184	270	926
680	1 433	980	1 175	280	917
690	1 425	990	1 167	290	909
-	-	-	-	5 300	900

8.6 Table 1<sub>6</sub>: Loading gauge accepted by BLS, SBB

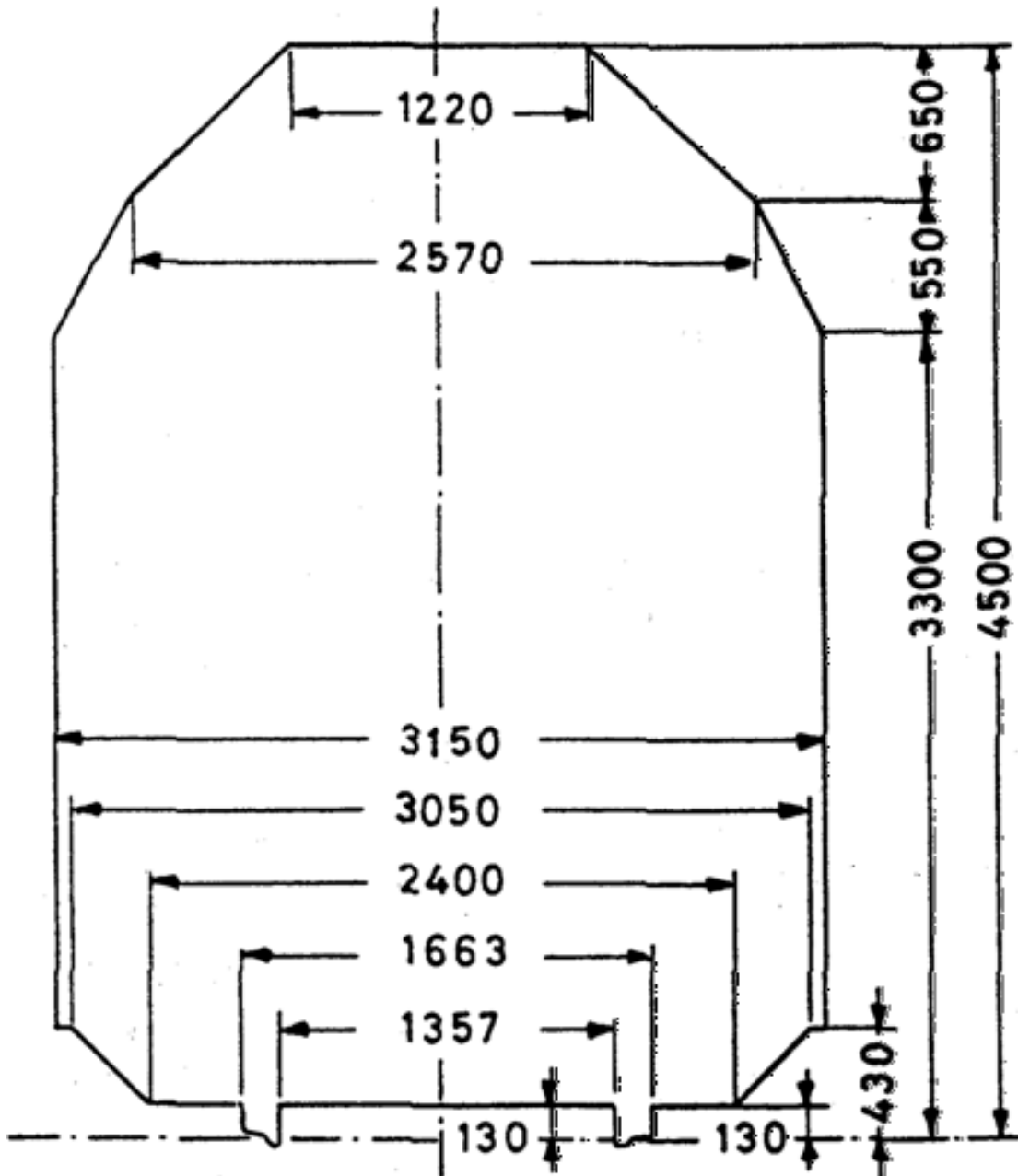

## Half-widths of the gauge

Height above rail level mm	Corresponding half-width mm	Height above rail level mm	Corresponding half-width mm	Height above rail level mm	Corresponding half-width mm	Height above rail level mm	Corresponding half-width mm
3 300	1 575	3 600	1 417	3 900	1 233	4 200	922
310	1 570	610	1 412	910	1 223	210	911
320	1 565	620	1 406	920	1 212	220	901
330	1 559	630	1 401	930	1 202	230	890
340	1 554	640	1 396	940	1 192	240	880
3 350	1 549	3 650	1 390	3 950	1 181	4 250	870
360	1 543	660	1 385	960	1 171	260	859
370	1 538	670	1 380	970	1 160	270	849
380	1 533	680	1 375	980	1 150	280	838
390	1 528	690	1 369	990	1 140	290	828
3 400	1 522	3 700	1 364	4 000	1 129	4 300	818
410	1 517	710	1 359	010	1 119	310	807
420	1 512	720	1 354	020	1 108	320	797
430	1 507	730	1 348	030	1 098	330	787
440	1 501	740	1 343	040	1 088	340	776
3 450	1 496	3 750	1 338	4 050	1 077	4 350	766
460	1 491	760	1 333	060	1 067	360	755
470	1 485	770	1 327	070	1 057	370	745
480	1 480	780	1 322	080	1 046	380	735
490	1 475	790	1 317	090	1 036	390	724
3 500	1 470	3 800	1 311	4 100	1 025	4 400	714
510	1 464	810	1 306	110	1 015	410	703
520	1 459	820	1 301	120	1 005	420	693
530	1 454	830	1 296	130	994	430	683
540	1 449	840	1 290	140	984	440	672
3 550	1 443	3 850	1 285	4 150	973	4 450	662
560	1 439	860	1 275	160	963	460	652
570	1 433	870	1 264	170	953	470	641
580	1 427	880	1 254	180	942	480	631
590	1 422	890	1 243	190	932	490	620
3 600	1 417	3 900	1 233	4 200	922	4 500	610

8.7 Table 17: Loading gauge accepted by FNME, FS

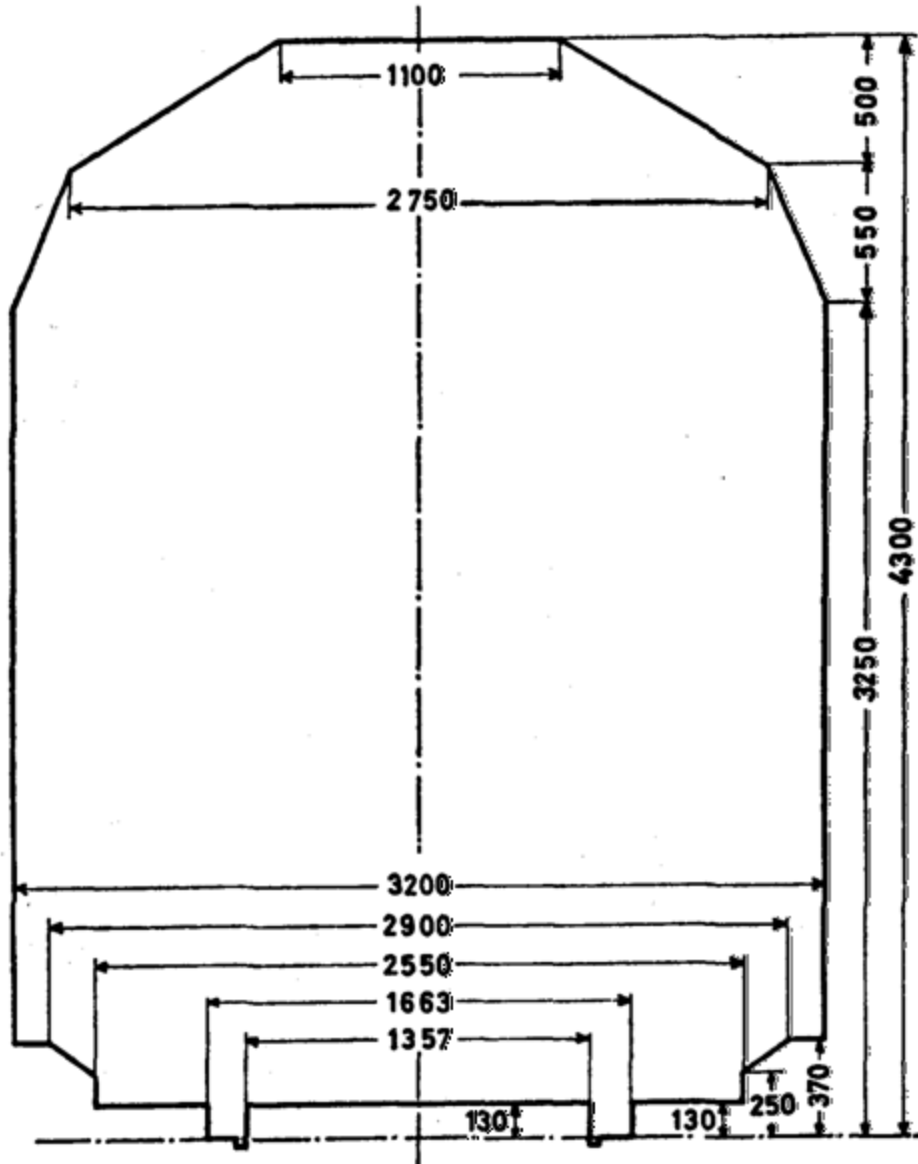

## Half-widths of the gauge

Height above rail level mm	Corresponding half-width mm	Height above rail level mm	Corresponding half-width mm	Height above rail level mm	Corresponding half-width mm	Height above rail level mm	Corresponding half-width mm
		3 500	1 498	3 800	1 375	4 100	880
		510	1 494	810	1 359	110	864
		520	1 490	820	1 342	120	847
		530	1 485	830	1 326	130	831
370	} 1 600	540	1 481	840	1 309	140	814
3 250		3 550	1 477	3 850	1 293	4 150	798
260	1 596	560	1 473	860	1 276	160	781
270	1 592	570	1 469	870	1 260	170	765
280	1 588	580	1 465	880	1 243	180	748
290	1 584	590	1 461	890	1 227	190	732
3 300	1 580	3 600	1 457	3 900	1 210	4 200	715
310	1 575	610	1 453	910	1 194	210	699
320	1 571	620	1 449	920	1 177	220	682
330	1 567	630	1 445	930	1 161	230	666
340	1 563	640	1 440	940	1 144	240	649
3 350	1 559	3 650	1 436	3 950	1 128	4 250	633
360	1 555	660	1 432	960	1 111	260	616
370	1 551	670	1 428	970	1 095	270	600
380	1 547	680	1 424	980	1 078	280	583
390	1 543	690	1 420	990	1 062	290	567
3 400	1 539	3 700	1 416	4 000	1 045	4 300	550
410	1 535	710	1 412	010	1 029		
420	1 530	720	1 408	020	1 012		
430	1 526	730	1 404	030	996		
440	1 522	740	1 400	040	979		
3 450	1 518	3 750	1 395	4 050	963		
460	1 514	760	1 391	060	946		
470	1 510	770	1 387	070	930		
480	1 506	780	1 383	080	913		
490	1 502	790	1 379	090	897		
3 500	1 498	3 800	1 375	4 100	880		-



8.8 Table 1<sub>8</sub>: Loading gauge accepted in Great Britain

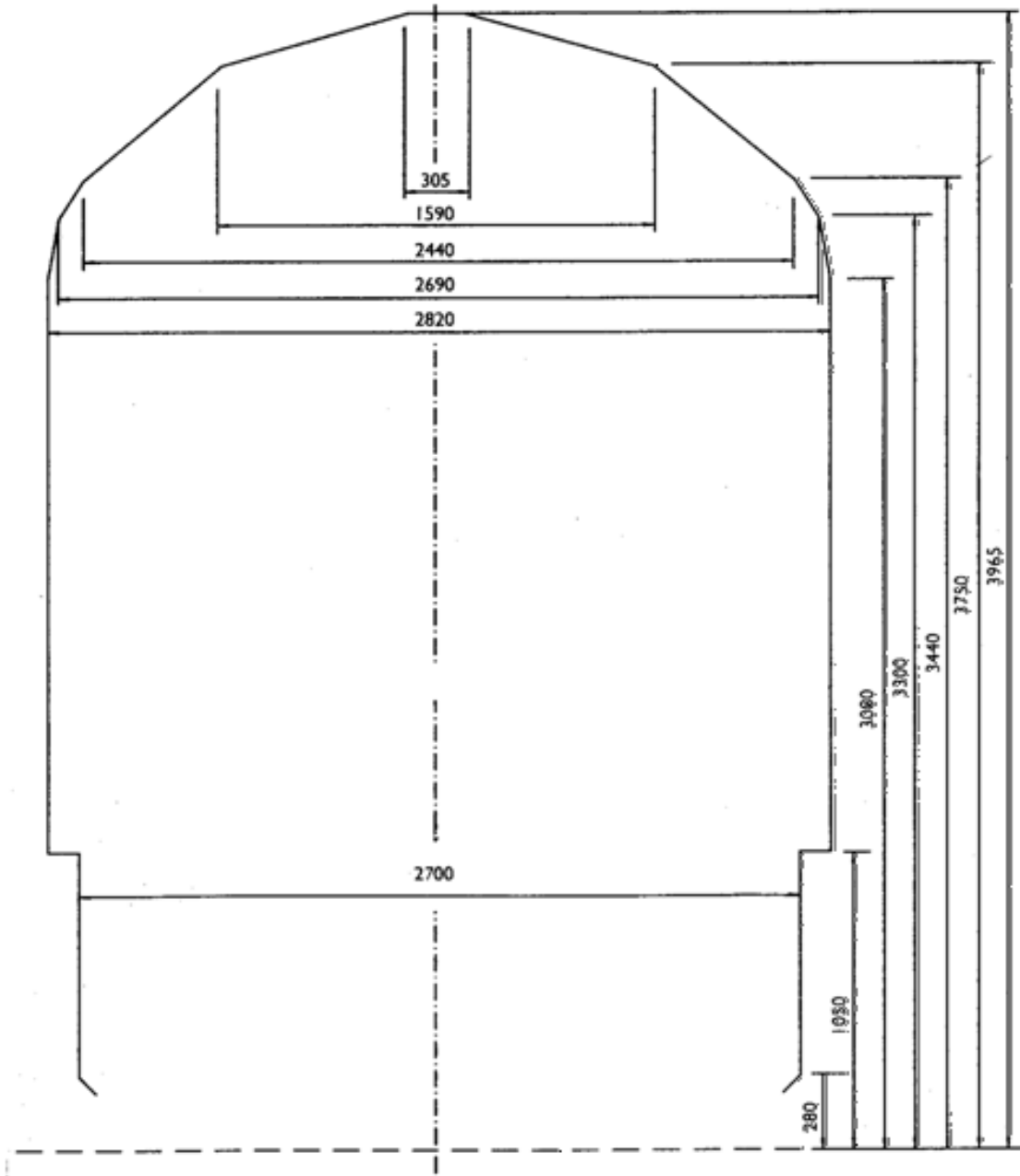

### Half-widths of the gauge

Height above rail level mm	Corresponding half-width mm	Height above rail level mm	Corresponding half-width mm	Height above rail level mm	Corresponding half-width mm
3 080	1 410	3 370	1 283	3 670	905
3 090	1 407	3 380	1 274	3 680	891
3 100	1 404	3 390	1 265	3 690	877
3 110	1 401	3 400	1 256	3 700	864
3 120	1 398	3 410	1 247	3 710	850
3 130	1 395	3 420	1 238	3 720	836
3 140	1 392	3 430	1 229	3 730	822
3 150	1 389	3 440	1 220	3 740	809
3 160	1 386	3 450	1 207	3 750	795
3 170	1 383	3 460	1 193	3 760	765
3 180	1 379	3 470	1 179	3 770	735
3 190	1 376	3 480	1 165	3 780	706
3 200	1 373	3 490	1 151	3 790	676
3 210	1 371	3 500	1 138	3 800	646
3 220	1 368	3 510	1 124	3 810	616
3 230	1 366	3 520	1 110	3 820	586
3 240	1 363	3 530	1 097	3 830	556
3 250	1 360	3 540	1 083	3 840	526
3 260	1 357	3 550	1 069	3 850	496
3 270	1 354	3 560	1 055	3 860	466
3 280	1 351	3 570	1 042	3 870	436
3 290	1 348	3 580	1 028	3 880	407
3 300	1 345	3 590	1 014	3 890	377
3 310	1 336	3 600	1 001	3 900	347
3 320	1 327	3 610	987	3 910	317
3 330	1 318	3 620	973	3 920	287
3 340	1 309	3 630	960	3 930	257
3 350	1 300	3 640	946	3 940	227
3 360	1 291	3 650	932	3 950	197
		3 660	918	3 965	152.5

8.9 Table 1<sub>9</sub>: Loading gauge accepted by RENFE, CP

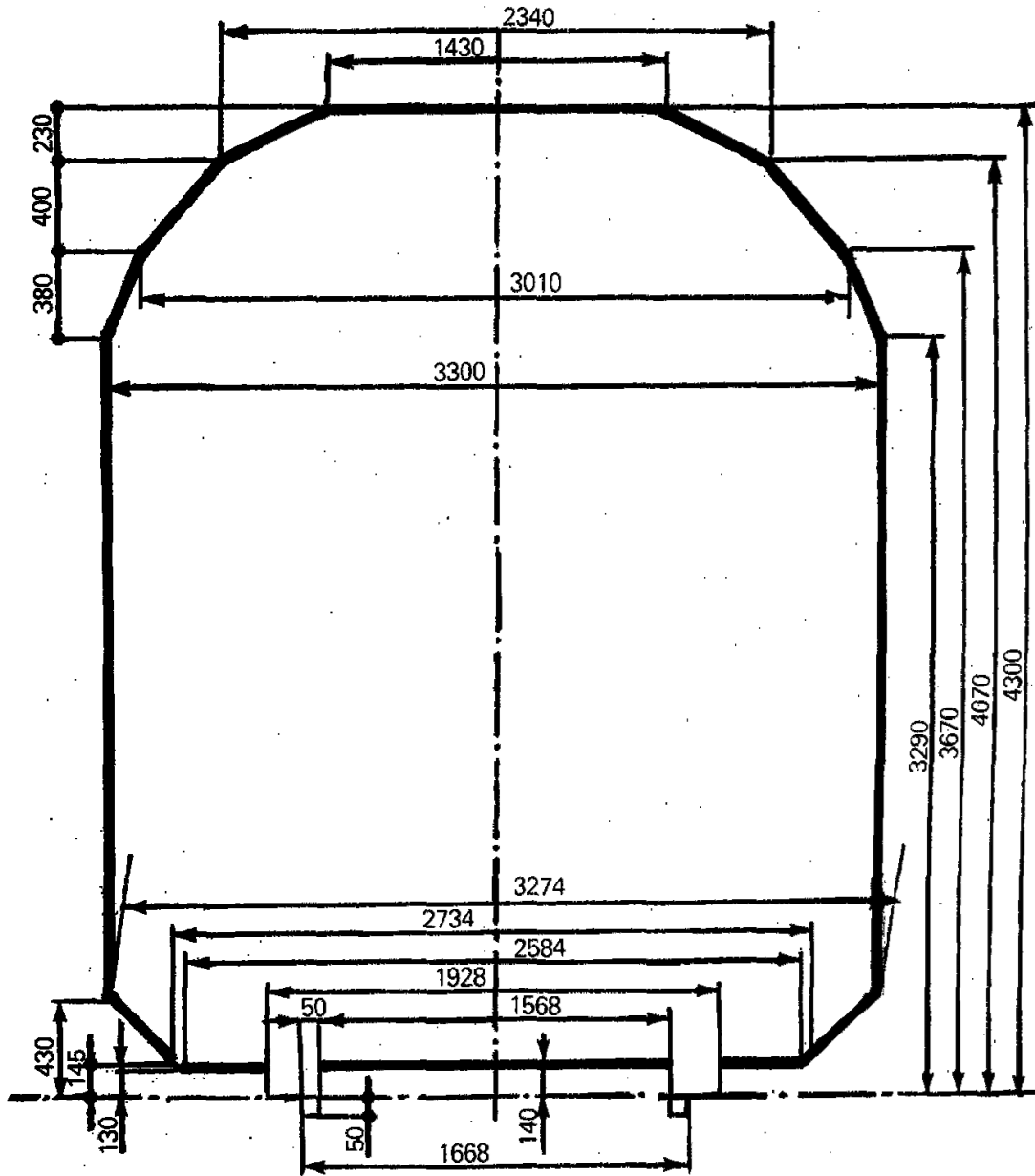

### Half-widths of the gauge

Height above rail level mm	Corresponding half-width mm	Height above rail level mm	Corresponding half-width mm	Height above rail level mm	Corresponding half-width mm	Height above rail level mm	Corresponding half-width mm
430 3 290	} 1 650						
3 300		1 646	3 600	1 532	3 900	1 312	4 200
310	1 642	610	1 528	910	1 304	210	893
320	1 638	620	1 524	920	1 296	220	873
330	1 635	630	1 520	930	1 287	230	853
340	1 631	640	1 516	940	1 279	240	834
350	1 627	650	1 513	950	1 270	250	814
360	1 623	660	1 509	960	1 262	260	794
370	1 619	670	1 505	970	1 254	270	774
380	1 616	680	1 497	980	1 245	280	755
390	1 612	690	1 488	990	1 237	290	735
3 400	1 608	3 700	1 480	4 000	1 229	4 300	715
410	1 604	710	1 471	010	1 220		
420	1 600	720	1 463	020	1 212		
430	1 597	730	1 455	030	1 203		
440	1 593	740	1 446	040	1 195		
450	1 589	750	1 438	050	1 187		
460	1 585	760	1 430	060	1 178		
470	1 581	770	1 421	070	1 170		
480	1 577	780	1 413	080	1 150		
490	1 574	790	1 404	090	1 130		
3 500	1 570	3 800	1 396	4 100	1 111		
510	1 566	810	1 388	110	1 091		
520	1 562	820	1 379	120	1 071		
530	1 558	830	1 371	130	1 051		
540	1 555	840	1 363	140	1 031		
550	1 551	850	1 354	150	1 012		
560	1 547	860	1 346	160	992		
570	1 543	870	1 337	170	972		
580	1 539	880	1 329	180	952		
590	1 535	890	1 321	190	933		
3 600	1 532	3 900	1 312	4 200	913		-

8.10 Table 1<sub>10</sub>: Loading gauge accepted by TRAFIKVERKET (Sweden)

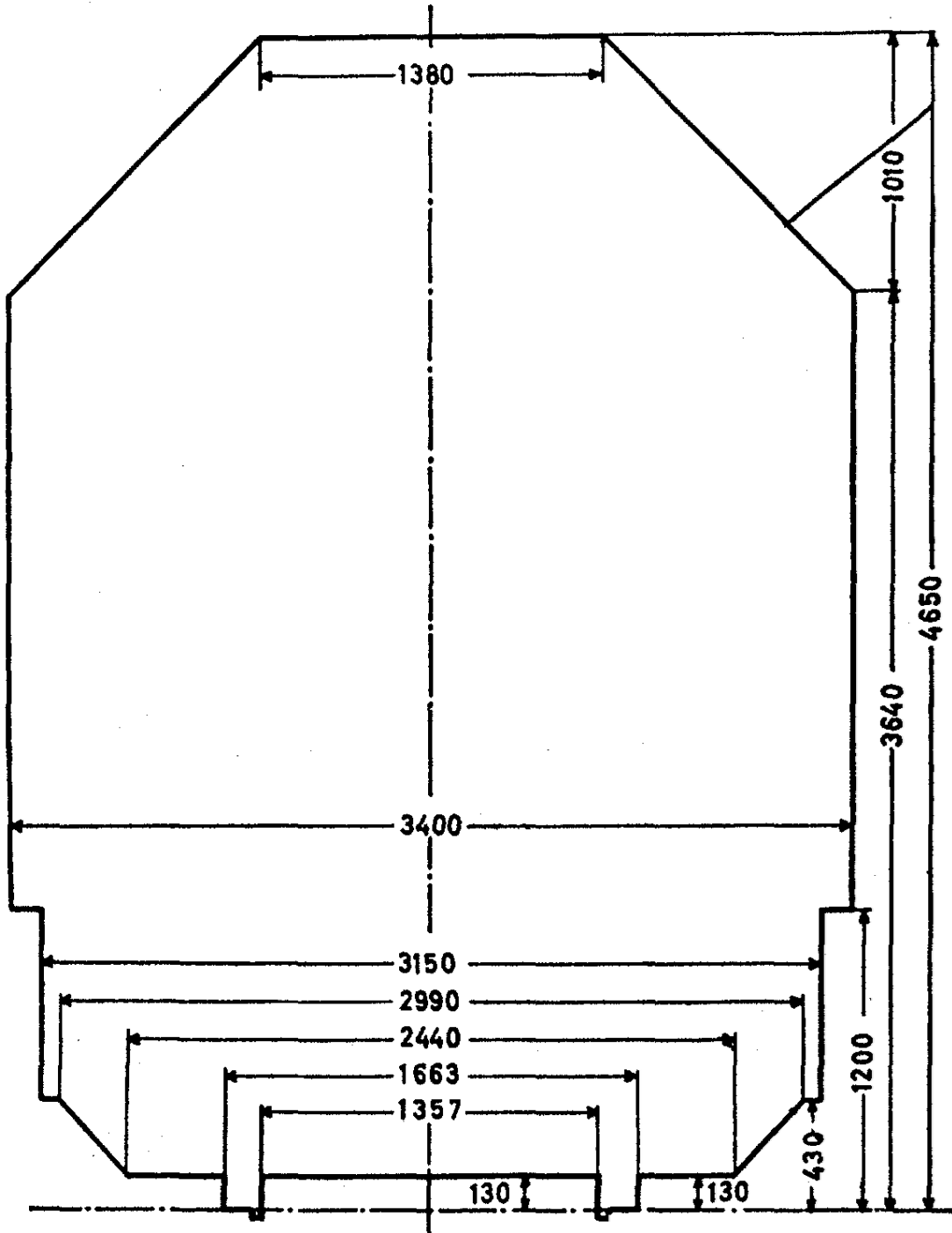

### Half-widths of the gauge

Height above rail level mm	Corresponding half-width mm	Height above rail level mm	Corresponding half-width mm	Height above rail level mm	Corresponding half-width mm	Height above rail level mm	Corresponding half-width mm
		3 900	1 440	4 200	1 140	4 500	840
430	1 575	910	1 430	210	1 130	510	830
1 200		920	1 420	220	1 120	520	820
1 200	1 700	930	1 410	230	1 110	530	810
3 640		940	1 400	240	1 100	540	800
3 650	1 690	3 950	1 390	4 250	1 090	4 550	790
660	1 680	960	1 380	260	1 080	560	780
670	1 670	970	1 370	270	1 070	570	770
680	1 660	980	1 360	280	1 060	580	760
690	1 650	990	1 350	290	1 050	590	750
3 700	1 640	4 000	1 340	4 300	1 040	4 600	740
710	1 630	010	1 330	310	1 030	610	730
720	1 620	020	1 320	320	1 020	620	720
730	1 610	030	1 310	330	1 010	630	710
740	1 600	040	1 300	340	1 000	640	700
3 750	1 590	4 050	1 290	4 350	990	4 650	690
760	1 580	060	1 280	360	980		
770	1 570	070	1 270	370	970		
780	1 560	080	1 260	380	960		
790	1 550	090	1 250	390	950		
3 800	1 540	4 100	1 240	4 400	940		
810	1 530	110	1 230	410	930		
820	1 520	120	1 220	420	920		
830	1 510	130	1 210	430	910		
840	1 500	140	1 200	440	900		
3 850	1 490	4 150	1 190	4 450	890		
860	1 480	160	1 180	460	880		
870	1 470	170	1 170	470	870		
880	1 460	180	1 160	480	860		
890	1 450	190	1 150	490	850		
3 900	1 440	4 200	1 140	4 500	840		

8.11 Table 1<sub>11</sub>: reserved





**8.12 Table 1<sub>12</sub> Loading gauge accepted by TCDD**

For the following

- line: KAPIKULE-EDIRNE
- destination stations: KAPIKULE, EDIRNE

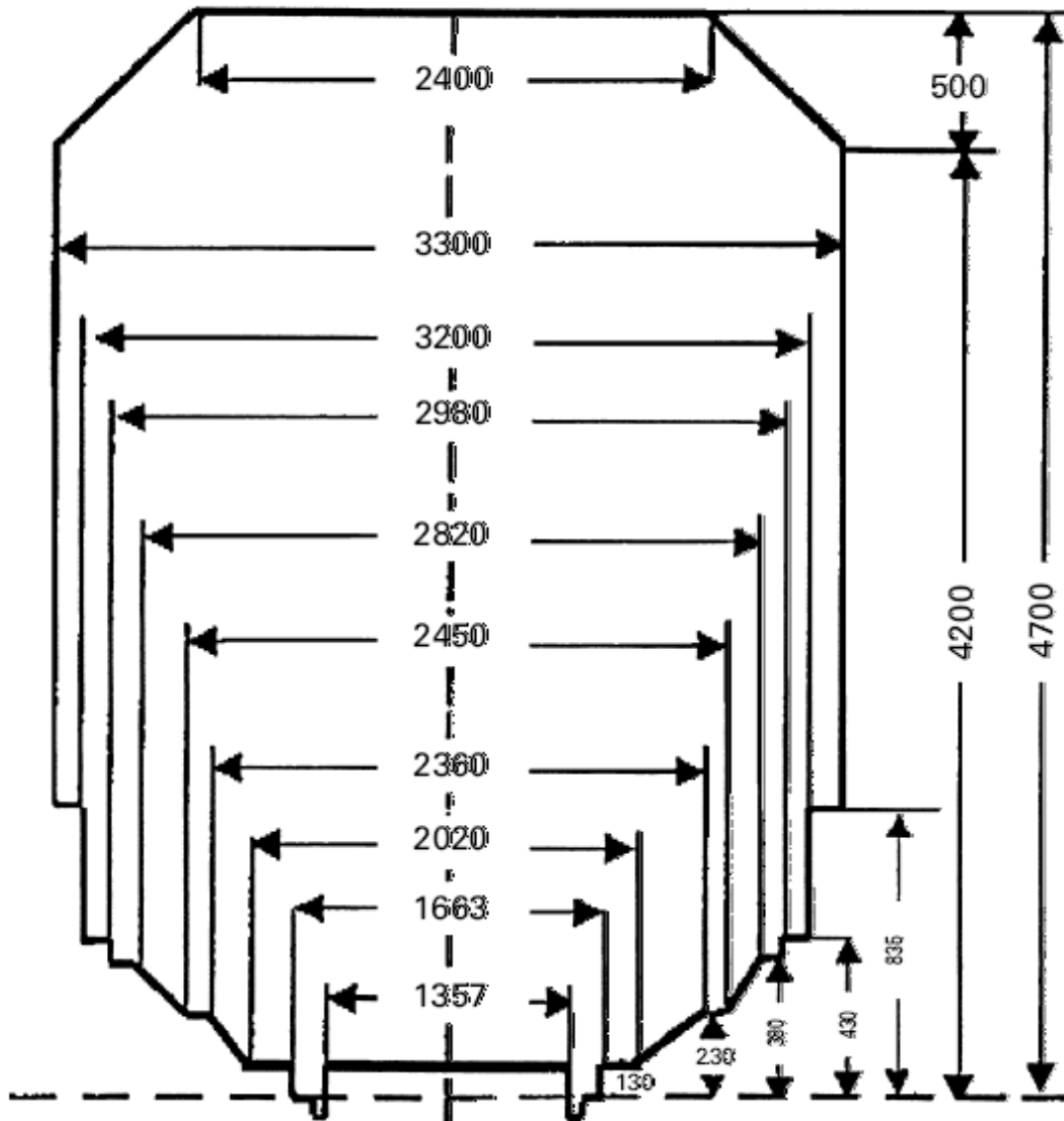

For other stations see tables 1<sub>4</sub>, 1<sub>13</sub> and 1<sub>14</sub>

**Half-widths of the gauge**

Height above rail level mm	Corresponding half-width mm	Height above rail level mm	Corresponding half-width mm
430 835	} 1 600		
835 4 200	} 1 650	4 450	1 435
210	1 640	460	1 428
220	1 630	470	1 421
230	1 620	480	1 414
240	1 610	490	1 407
4 250	1 600	4 500	1 400
260	1 590	510	1 390
270	1 580	520	1 380
280	1 570	530	1 370
290	1 560	540	1 360
4 300	1 550	4 550	1 350
310	1 540	560	1 340
320	1 530	570	1 330
330	1 520	580	1 320
340	1 510	590	1 310
4 350	1 500	4 600	1 300
360	1 490	610	1 290
370	1 480	620	1 280
380	1 470	630	1 270
390	1 460	640	1 260
4 400	1 450	4 650	1 250
410	1 445	660	1 240
420	1 440	670	1 230
430	1 435	680	1 220
440	1 430	690	1 210
4 450	1 435	4 700	1 200

**8.13 Table 1<sub>13</sub>: Loading gauge accepted by TCDD**

For the following

- line: EDIRNE-HALKALI
- destination stations: ALPULLU, LULEBURGAZ, MURATLI, CORLU, CERKEZKOY, HALKALI

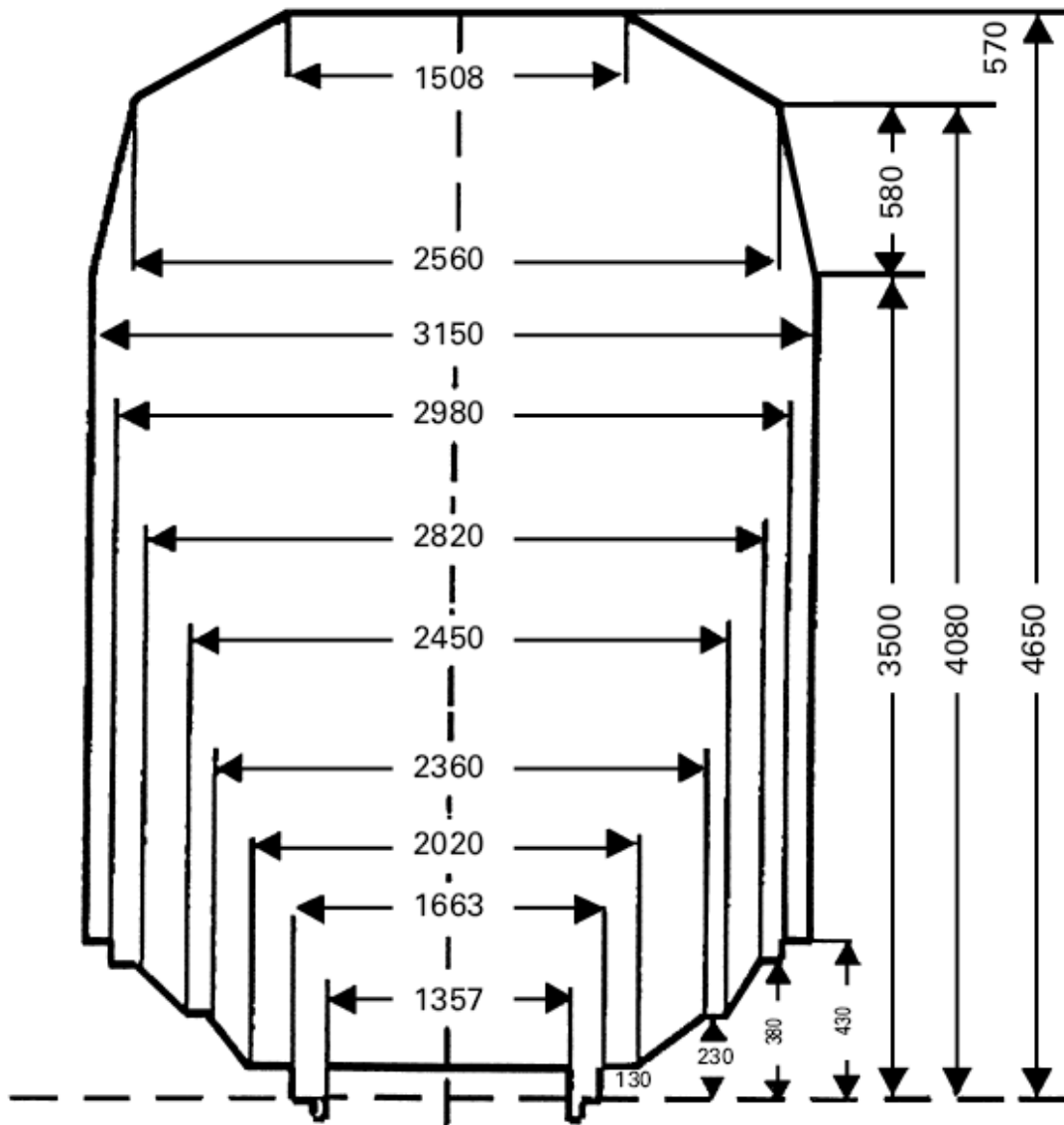

For other stations see tables 1<sub>4</sub>, 1<sub>12</sub> and 1<sub>14</sub>

### Half-widths of the gauge

Height above rail level mm	Corresponding half-width mm	Height above rail level mm	Corresponding half-width mm	Height above rail level mm	Corresponding half-width mm	Height above rail level mm	Corresponding half-width mm
430 3 500	1 575	3 800	1 422	4 100	1 262	4 400	985
510 520 530 540 3 550							
560 570 580 590 3 600	1 544 1 539 1 534 1 529 1 524	860 870 880 890 3 900	1 392 1 387 1 382 1 377 1 372	160 170 180 190 4 200	1 206 1 197 1 188 1 178 1 169	460 470 480 490 4 500	929 920 911 902 892
610 620 630 640 3 650	1 519 1 514 1 509 1 504 1 499	910 920 930 940 3 950	1 366 1 361 1 356 1 351 1 346	210 220 230 240 4 250	1 160 1 151 1 142 1 132 1 123	510 520 530 540 4 550	883 874 865 855 846
660 670 680 690 3 700	1 494 1 489 1 483 1 478 1 473	960 970 980 990 4 000	1 341 1 336 1 331 1 326 1 321	260 270 280 290 4 300	1 114 1 105 1 095 1 086 1 077	560 570 580 590 4 600	837 828 818 809 800
710 720 730 740 3 750	1 468 1 463 1 458 1 453 1 448	010 020 030 040 4 050	1 316 1 311 1 305 1 300 1 295	310 320 330 340 4 350	1 068 1 058 1 049 1 040 1 031	610 620 630 640 4 650	791 782 772 763 754
760 770 780 790 3 800	1 443 1 438 1 433 1 428 1 422	060 070 080 090 4 100	1 290 1 285 1 280 1 271 1 262	360 370 380 390 4 400	1 022 1 012 1 003 994 985		

**8.14 Table 1<sub>14</sub>: Loading gauge accepted by TCDD**

For the following

- line: VAN-KAPIKOY
- destination stations: VAN, KAPIKOYI

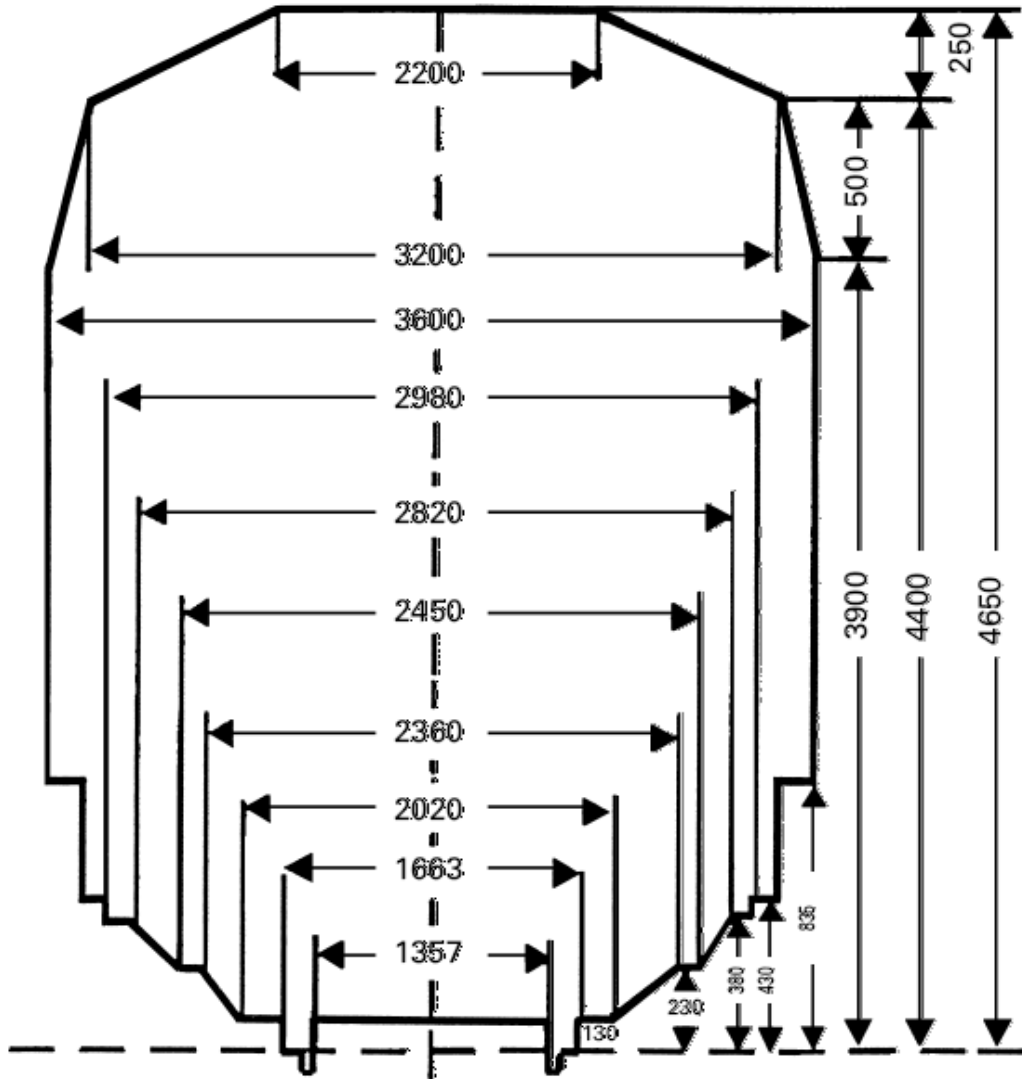

For other stations see tables 1<sub>4</sub>, 1<sub>12</sub> and 1<sub>13</sub>

### Half-width of the gauge

Height above rail level mm	Corresponding half-width mm	Height above rail level mm	Corresponding half-width mm	Height above rail level mm	Corresponding half-width mm	
830	1 600					
835						
835		1 800				
900			4 200	1 660	4 500	1 400
910	1 795	210	1 658	510	1 380	
920	1 787	220	1 656	520	1 360	
930	1 780	230	1 654	530	1 340	
940	1 774	240	1 652	540	1 320	
950	1 760	4 250	1 650	4 550	1 300	
960	1 756	260	1 648	560	1 280	
970	1 752	270	1 646	570	1 260	
980	1 748	280	1 644	580	1 240	
990	1 744	290	1 642	590	1 220	
000	1 740	4 300	1 640	4 600	1 200	
010	1 738	310	1 636	610	1 180	
020	1 736	320	1 632	620	1 160	
030	1 734	330	1 628	630	1 140	
040	1 732	340	1 624	640	1 120	
050	1 730	4 350	1 620	4 650	1 100	
060	1 726	360	1 616			
070	1 722	370	1 612			
080	1 718	380	1 608			
090	1 714	390	1 604			
100	1 710	4 400	1 600			
110	1 708	410	1 580			
120	1 706	420	1 560			
130	1 704	430	1 540			
140	1 702	440	1 520			
150	1 700	4 450	1 500			
160	1 692	460	1 480			
170	1 684	470	1 460			
180	1 676	480	1 440			
190	1 668	490	1 420			
1 200	1 660	4 500	1 400			

8.15 Table 1<sub>15</sub>: Loading gauge accepted by C (NSB)

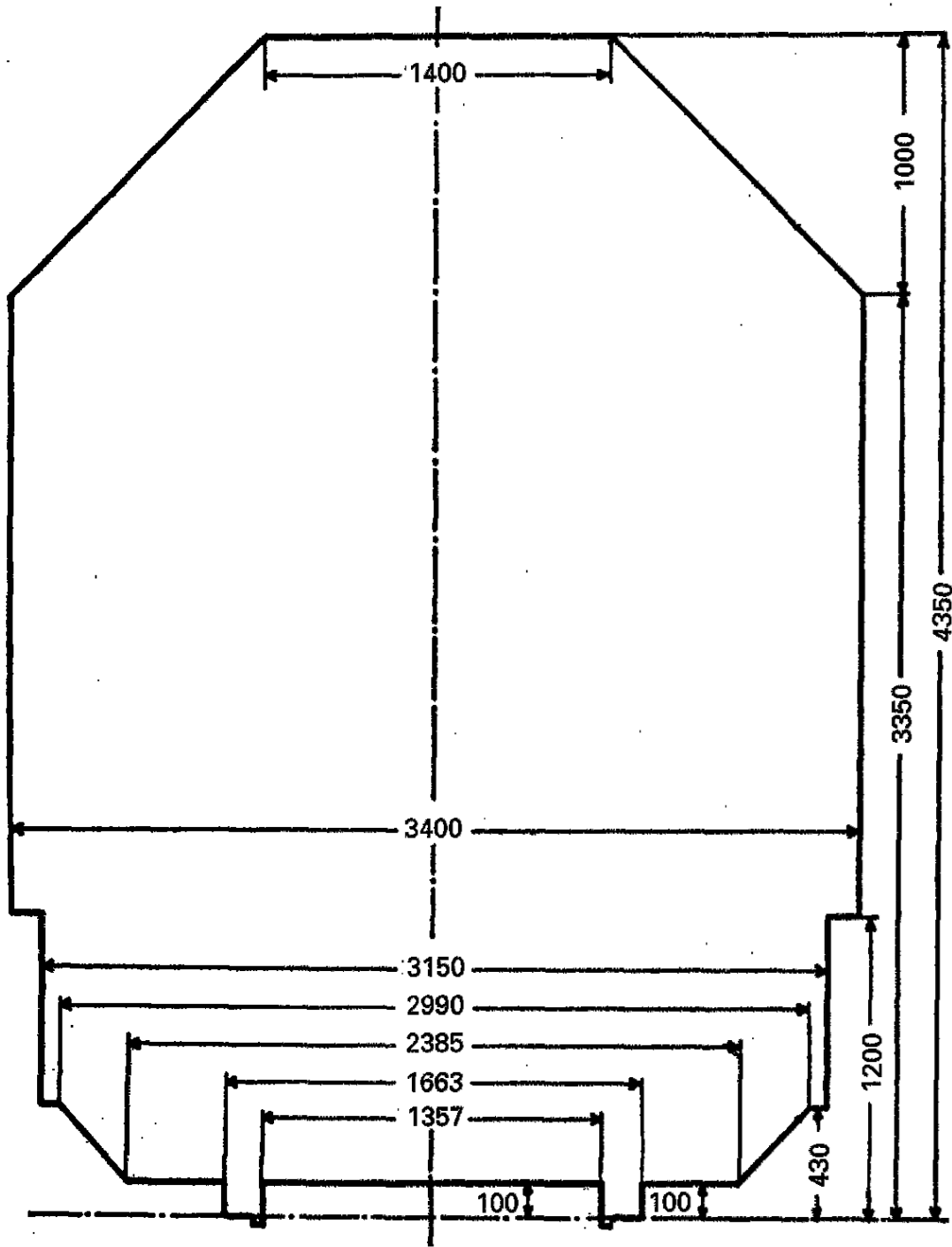

### Half-widths of the gauge

Height above rail level mm	Corresponding half-width mm	Height above rail level mm	Corresponding half-width mm	Height above rail level mm	Corresponding half-width mm	Height above rail level mm	Corresponding half-width mm
		3 550	1 500	3 850	1 200	4 150	900
430 1 200	} 1 575	560	1 490	860	1 190	160	890
		570	1 480	870	1 180	170	880
		580	1 470	880	1 170	180	870
		590	1 460	890	1 160	190	860
		3 600	1 450	3 900	1 150	4 200	850
1 200 3 350	} 1 700	610	1 440	910	1 140	210	840
		620	1 430	920	1 130	220	830
		630	1 420	930	1 120	230	820
		640	1 410	940	1 110	240	810
3 350	1 700	3 650	1 400	3 950	1 100	4 250	800
360	1 690	660	1 390	960	1 090	260	790
370	1 680	670	1 380	970	1 080	270	780
380	1 670	680	1 370	980	1 070	280	770
390	1 660	690	1 360	990	1 060	290	760
3 400	1 650	3 700	1 350	4 000	1 050	4 300	750
410	1 640	710	1 340	010	1 040	310	740
420	1 630	720	1 330	020	1 030	320	730
430	1 620	730	1 320	030	1 020	330	720
440	1 610	740	1 310	040	1 010	340	710
3 450	1 600	3 750	1 300	4 050	1 000	4 350	700
460	1 590	760	1 290	060	990		
470	1 580	770	1 280	070	980		
480	1 570	780	1 270	080	970		
490	1 560	790	1 260	090	960		
3 500	1 550	3 800	1 250	4 100	950		
510	1 540	810	1 240	110	940		
520	1 530	820	1 230	120	930		
530	1 520	830	1 220	130	920		
540	1 510	840	1 210	140	910		
3 550	1 500	3 850	1 200	4 150	900		



8.16 Table 1<sub>16</sub>: Loading gauge accepted by SNCB

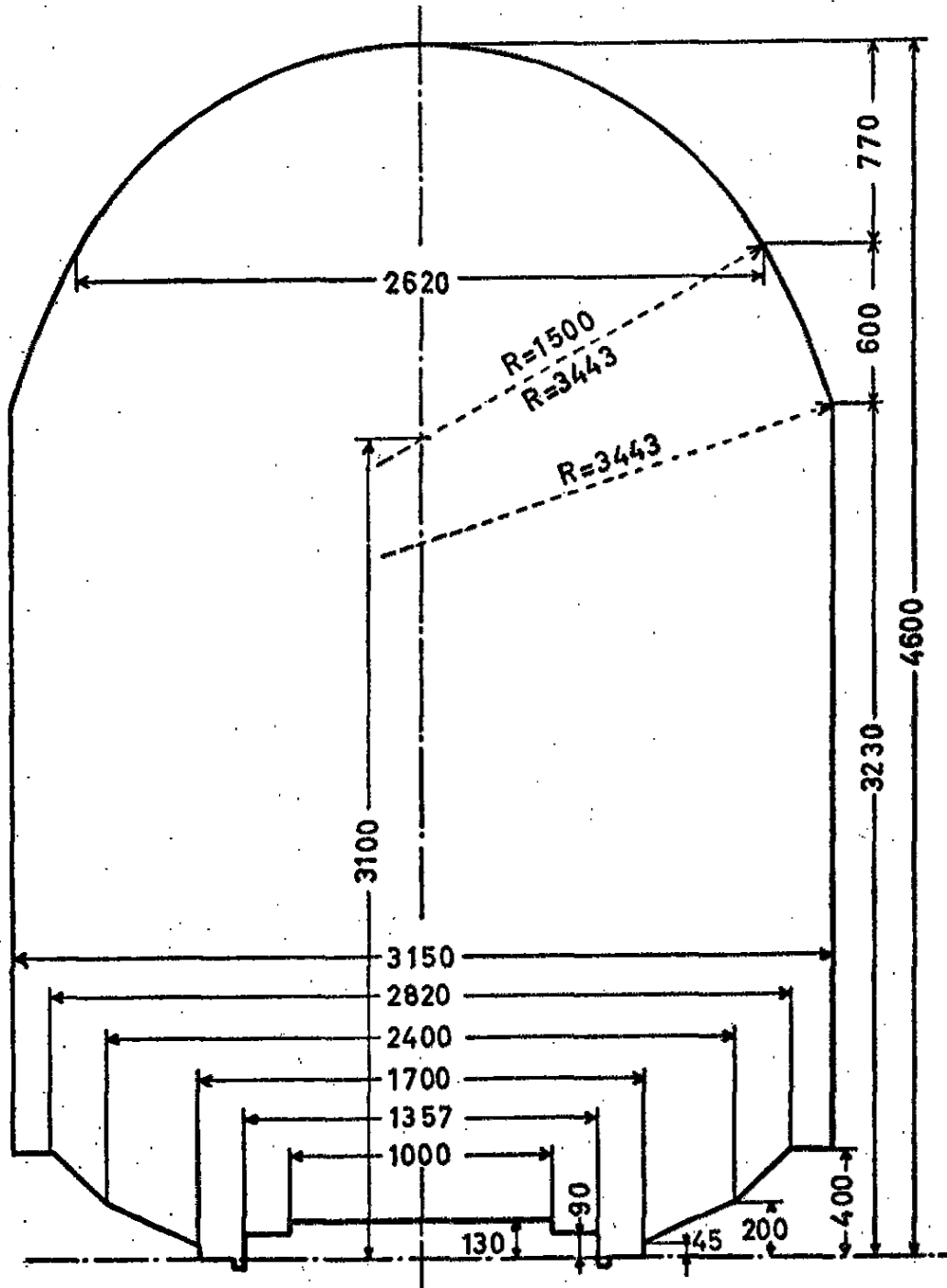

With the exception of the stations:

BEIGNEE, BERZEE, COUR-SUR-HEURE, COUVIN, HAM-SUR-HEURE, JAMILOUX, MARIEMBOURG, PHILIPPEVILLE, PRY, WALCOURT and YVES-GOMEZEE

For other stations see table 1<sub>1</sub>.

### Half-widths of the gauge

Height above rail level mm	Corresponding half-width mm	Height above rail level mm	Corresponding half-width mm	Height above rail level mm	Corresponding half-width mm
400	1 575	710	1 374	210	1 009
3 230		720	1 369	220	998
240		730	1 363	230	986
3 250		740	1 358	240	975
		3 750	1 353	4 250	963
260	1 565	760	1 348	260	951
270	1 562	770	1 342	270	939
280	1 558	780	1 337	280	926
290	1 554	790	1 332	290	913
3 300	1 551	3 800	1 326	4 300	900
310	1 547	810	1 321	310	886
320	1 544	820	1 315	320	873
330	1 540	830	1 310	330	858
340	1 536	840	1 305	340	844
3 350	1 532	3 850	1 299	4 350	829
360	1 529	860	1 293	360	814
370	1 525	870	1 287	370	798
380	1 521	880	1 281	380	782
390	1 517	890	1 275	390	765
3 400	1 513	3 900	1 269	4 400	748
410	1 509	910	1 262	410	731
420	1 505	920	1 256	420	712
430	1 501	930	1 249	430	694
440	1 497	940	1 243	440	674
3 450	1 493	3 950	1 236	4 450	654
460	1 489	960	1 229	460	633
470	1 485	970	1 222	470	611
480	1 481	980	1 215	480	588
490	1 476	990	1 207	490	564
3 500	1 472	4 000	1 200	4 500	538
510	1 468	010	1 192	510	512
520	1 464	020	1 185	520	483
530	1 459	030	1 177	530	453
540	1 455	040	1 169	540	420
3 550	1 450	4 050	1 161	4 550	384
560	1 446	060	1 153	560	344
570	1 441	070	1 144	570	298
580	1 437	080	1 136	580	244
590	1 432	090	1 127	590	173
3 600	1 427	4 100	1 118	4 600	-
610	1 423	110	1 109		
620	1 418	120	1 100		
630	1 413	130	1 090		
640	1 408	140	1 081		
3 650	1 404	4 150	1 071		
660	1 399	160	1 061		
670	1 394	170	1 051		
680	1 389	180	1 041		
690	1 384	190	1 030		
3 700	1 379	4 200	1 020		

8.17 Table 1<sub>17</sub>: Loading gauge accepted by RAI

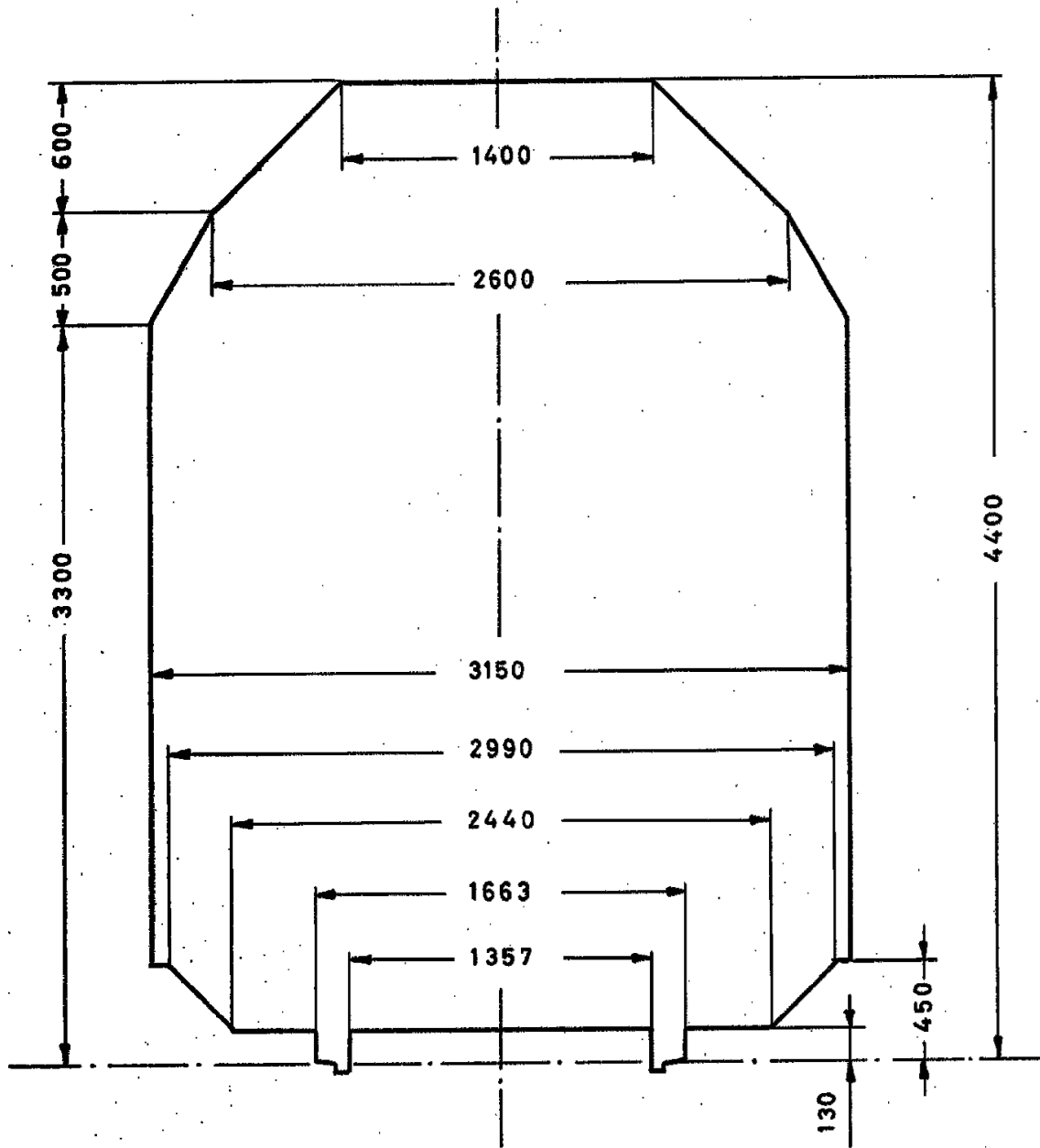

### Half-widths of the gauge

Height above rail level mm	Corresponding half-width mm	Height above rail level mm	Corresponding half-width mm	Height above rail level mm	Corresponding half-width mm	Height above rail level mm	Corresponding half-width mm
3 300	1 575	3 600	1 410	3 900	1 200	4 200	900
310	1 570	610	1 405	910	1 190	210	890
320	1 564	620	1 399	920	1 180	220	880
330	1 559	630	1 394	930	1 170	230	870
340	1 553	640	1 388	940	1 160	240	860
3 350	1 548	3 650	1 383	3 950	1 150	4 250	850
360	1 542	660	1 377	960	1 140	260	840
370	1 537	670	1 372	970	1 130	270	830
380	1 531	680	1 366	980	1 120	280	820
390	1 526	690	1 361	990	1 110	290	810
3 400	1 520	3 700	1 355	4 000	1 100	4 300	800
410	1 515	710	1 350	010	1 090	310	790
420	1 509	720	1 344	020	1 080	320	780
430	1 504	730	1 339	030	1 070	330	770
440	1 498	740	1 333	040	1 060	340	760
3 450	1 493	3 750	1 328	4 050	1 050	4 350	750
460	1 487	760	1 322	060	1 040	360	740
470	1 482	770	1 317	070	1 030	370	730
480	1 476	780	1 311	080	1 020	380	720
490	1 471	790	1 306	090	1 010	390	710
3 500	1 465	3 800	1 300	4 100	1 000	4 400	700
510	1 460	810	1 290	110	990		
520	1 454	820	1 280	120	980		
530	1 449	830	1 270	130	970		
540	1 443	840	1 260	140	960		
3 550	1 438	3 850	1 250	4 150	950		
560	1 432	860	1 240	160	940		
570	1 427	870	1 230	170	930		
580	1 421	880	1 220	180	920		
590	1 416	890	1 210	190	910		
3 600	1 410	3 900	1 200	4 200	900		

**8.18 Table 1<sub>18</sub>: SNCF**

Wagons loaded to the GB gauge shall be accepted as special consignments in accordance with UIC Leaflet 502 covered by permanent authorisation **ATE 40 00 481 045** via the following frontier points: TOURCOING, FEIGNIES, JEUMONT, ZOUFFTGEN, APACH, FORBACH, LAUTERBOURG et KEHL, destined for the following stations:

ABBEVILLE	AUXERRE-SAINT-GERVAIS	BOISLEUX
ACHERES-TRIAGE	AVALLON	BOLLENE-LA-CROISIERE
ACHIET	AVESNES	BON-ENCONTRE
AGEN	AVIGNON	BONNARD-BASSOU
AIGREFEUILLE-LE-THOU	AYTRE	BONNEVAL
AIGUEBELLE	BACCARAT	BONNIERES
AIGUEPERSE	BACOUEL	BORDEAUX-BASTIDE
AIGUES-VIVES	BAIGTS-DE-BEARN	BORDEAUX-HOURCADE
AILLEVILLERS	BAINS-LES-BAINS	BORDEAUX-PASSERELLE
AILLY-SUR-NOYE	BALE	BORDEAUX-SAINT-JEAN
AIRVAULT-GARE	BALE-MARCHANDISES	BORDEAUX-SAINT-LOUIS
AIX-MARCHANDISES	BALE-SAINT-JEAN	BOUCAU
ALBERT	BALE-VOYAGEURS	BOUCHAIN
ALBERTVILLE	BANNALEC	BOULOU-PERTHUS (LE)
ALBI-VILLE	BANYULS-DELS-ASPRES	BOURG-EN-BRESSE
ALENCON	BAPAUME	BOURGET (LE)
ALIXAN-CHATEAUNEUF-D'ISERE	BARBENTANE-ROGNONAS	BOURGET-TRIAGE (LE)
ALLONNES-BOISVILLE	BADDYS (LES)	BOURGOIN-JALLIEU
ALTKIRCH	BAR-LE-DUC	BOURG-SAINT-AURICE
AMAGNE-LUCQUY	BARONCOURT	BOURRON-MARLOTTE
AMBAZAC	BASSENS-APPONTEMENTS	BOUSSENS
AMBERIEU	BASTA-LES-FORGES	BOUZONVILLE
AMBOISE	BATHIE (LA)	BRAM
AMBRONAY-PRIAY	BAYONNE	BRAY-DUNES (FRONTIERE)
AMIENS	BAZANCOURT	BRAZEY-EN-PLAINE
AMIFONTAINE	BAZEILLES	BREAUTE-BEUZEVILLE
ANGERS-SAINT-LAUD	BAZIEGE	BREST-BASSINS
ANGOULEME	BEAUCAIRE-MARCHANDISES	BRETEUIL-EMBRANCHEMENT
ANOR	BEAUGENCY	BRETIGNY
APACH (Moselle)	BEAULIEU-LE-COUDRAY	BRETONCELLES
APACH-FRONTIERE	BEAUNE	BRICY-BOULAY
ARAMON	BEAUVAIS	BRIENON
ARCHES	BEGLES	BRIVE-LA-GAILLARDE
ARGAGNON	BELFORT	BROHINIERE (LA)
ARGENTAN	BELLENAVES	BRUGES
ARGENTEUIL	BELLEVILLE	BRUMATH
ARGENTON-SUR-CREUSE	BELLEVILLE-SUR-SAONE	BRUYERES (Vosges)
ARLES	BENESTROFF	BRY-SUR-MARNE
ARMENTIERES	BENING	BUISSON (LE)
ARNAGE	BERGERAC	BULLY-GRENAY
ARQUES (Pas-de-Calais)	BERGUES	BUZY (Meuse)
ARRAS	BERLAIMONT	CALAIS-VILLE
ARRAS-MEAULENS	BERRE	CAMBRAI-ANNEXE
ARS-SUR-MOSELLE	BETHUNE	CAMBRAI-VILLE
ARTENAY (Loiret)	BEZIERS	CARBONNE
ARTIX	BIACHE-SAINT-VAAST	CARCASSONNE
ATTIN (GARAGE)	BIARRITZ	CARIGNAN
AUBAGNE	BISCHEIM	CARLING
AUBERGENVILLE-	BITCHE-LE-CAMP	CARPENTRAS
ELISABETHVILLE AUBIGNE-	BLAGNY	CASTELNAU D'ESTREFONDS
RACAN	BLAINVILLE-DAMELEVIERS	CASTELNAUDARY
AUBIGNY-SUR-NERE	BLAISY-BAS	CASTELSARRASIN
AUBRAIS-ORLEANS (LES)	BLANC-MESNIL (LE)	CASTRES (Tarn)
AULNAT	BLANGY-SUR-BRESLE	CATEAU (LE)
AULNOYE-AYMERIES	BLANQUEFORT	CAUDERAN-MERIGNAC
AUMALE	BLEUSE-BORNE (LA) (Garage)	CAUDRY
AUNEAU	BLOIS	CAVAILLON
AURAY	BOBIGNY-G.C.	
	BOHAIN	

CAZERES  
CERBERE  
CERCY-LA-TOUR  
CHAGNY  
CHALONS-EN-CHAMPAGNE  
CHALON-SUR-SAONE  
CHALON-SUR-SAONE (PORT-  
NORD)  
CHAMBERY-CHALLES-LES-  
EAUX  
CHAMPAGNE  
CHAMPIGNEULLES  
CHANDIEU-TOUSSIEU  
CHANGIS-SAINT-JEAN  
CHAPELLE-SUR-ERDE (LA)  
CHARITE (La)  
CHARMANT  
CHARMES (Vosges)  
CHARS  
CHARTRES  
CHASSENEUIL (Vienne)  
CHATEAUBRIANT  
CHATEAU-DU-LOIR  
CHATEAUDUN  
CHATEAU-GONTIER  
CHATEAULIN-  
EMBRANCHEMENT  
CHÂTEAUNEUF-SUR-  
CHARENTE CHATEAUROUX  
CHATEAU-THIERRY  
CHÂTELAUDREN-PLOUAGAT  
CHATEL-CENSOIR  
CHATELET (LE)  
CHATELLERAULT  
CHATEL-NOMEXY  
CHATILLON-SUR-LOIRE  
CHAULNES  
CHECY-MARDIE  
CHELLES-GOURNAY  
CHEMILLY-APPOIGNY  
CHEVIGNY-SAINT-SAUVEUR  
(Garage)  
CHEVRIERES  
CHOCQUES  
CHOISY-LE-ROI  
CINTEGABELLE  
CLAMECY  
CLERMONT-FERRAND  
CLISSON  
COCHEREN  
COGNAC  
COLAYRAC  
COLLONGES-FONTAINES  
COLMAR  
COLOMBIERS  
COMMERCY  
COMPIEGNE  
CONDAT-LE-LARDIN  
CONFLANS-FIN-D'OISE  
CONFLANS-JARNY  
CONNERRE-BEILLE  
CORBEHEM  
CORBEIL-ESSONNES  
CORBIE  
CORDEMAIS

COSNE  
COUCY-LES-EPPES  
COUDEKERQUE-BRANCHE  
COUHE-VERAC  
COULANGES-SUR-YONNE  
COULOMBIERS  
COURNEUVE-DUGNY (LA)  
COURONNE (LA)  
COURVILLE-SUR-EURE  
COUTRAS  
CRAVANT-BAZARNES  
CREIL  
CREPY-COUVRON  
CREPY-EN-VALOIS  
CREUSOT (LE)  
CREUTZWALD  
CROTELLES  
CROUY  
CRUAS  
CULOZ  
CUPERLY  
DAMMARTIN-JUILLY-SAINT-  
MARD  
DAOURS  
DARCEY (Côte-d'Or)  
DAX  
DECIZE  
DERCY-MORTIERS  
DIEMERINGEN  
DIEPPE  
DIEULOUARD  
DIJON-PORTE-NEUVE  
DINAN  
DIRINON  
DOCELLES-CHENIMENIL  
DOL  
DOMPIERRE-SUR-MER  
DONCHERY  
DONGES  
DON-SAINGHIN  
DOUAI  
DOULON  
DOURDAN  
DOURGES  
DREUX  
DUNKERQUE  
EBANGE  
ECOUFLANT  
EMPALOT (Garage)  
ENNEZAT-CLERLANDE  
ENTRAIGUES-SUR -LA-SORGUE  
ENTRESSEN  
EPERNAY  
EPIERRE-SAINT-LEGER  
EPINAL  
EPLUCHES  
EPONE-MEZIERES  
ERAGNY-NEUVILLE  
ESCALQUENS  
ESTAQUE (L')  
ETAMPES  
ETAPLES-LE-TOUQUET  
EU  
FACTURE  
FARGNIERS (Garage)

FAULQUEMONT  
FEIGNIES-FRONTIERE  
FENOUILLET  
FERE (LA)  
FERRIERES-FONTENAY  
FERTE-HAUTERIVE (LA)  
FERTE-SAINT-AUBIN (LA)  
FERTE-SOUS-JOUARRE (LA)  
FERTOT (Garage)  
FLAVY-LE-MARTEL  
FLIXECOURT  
FOIX  
FOLLIGNY  
FONTAINEBLEAU-AVON  
FORBACH  
FORBACH-FRONTIERE  
FORGENEUVES (Garage)  
FOUG  
FOUQUEREUIL  
FOURCHAMBAULT  
FOURMIES  
FRESNOY-LE-GRAND  
FREYMING-MERLEBACH  
FRONTENEX  
FRONTIGNAN  
FROUARD  
GAILLAC  
GAILLON-AUBEVOYE  
GANDRANGE-AMNEVILLE  
GANNAT  
GANNES  
GARGENVILLE  
GAZINET-CESTAS  
GENNES-LONGUEFUYE  
GENNEVILLIERS  
GENSAC-LA-PALLUE  
GERZAT  
GEVREY-CHAMBERTIN  
GEVREY-TRIAGE  
GIEN  
GISORS-EMBRANCHEMENT  
GIVORS-VILLE  
GOUSSAINVILLE  
GRAFFENSTADEN  
GRANVILLE  
GRENOBLE  
GRISOLLES  
GUIGNICOURT (Aisne)  
GUILLAUCOURT  
GUINGAMP  
HAGONDANGE  
HAM (SOMME)  
HANGEST  
HARGARTEN-FALCK  
HAUBOURDIN  
HAUSBERGEN  
HAUTMONT  
HAVRE (Le) HAYANGE  
HAZEBROUCK  
HELLEMMES-LILLE  
HEMING  
HENDAYE  
HENIN-BEAUMONT

HENNEBONT  
HERBERGEMENT-LES-  
BROUZILS  
HERICOURT (L')  
HERICY  
HERMITAGE-MORDELLES (L')  
HERRLISHEIM (BAS-RHIN)  
HESDIN  
HETTANGE-GRANDE  
HEYRIEUX  
HOCHFELDEN  
HOUDAN  
HUTTE-COULOMBIERS (LA)  
IMPHY  
INCHEVILLE  
INGRANDES-SUR-VIENNE  
IRUN  
ISBERGUES  
ISLE-FONTAINE-DE-VAUCLUSE  
ISSOUDUN (L')  
IS-SUR-TILLE  
IVRY-SUR-SEINE-FRET  
JALONS-LES-VIGNES  
JANZE  
JARNAC-CHARENTE  
JARVILLE-LA-MALGRANGE  
JAUNEY-CLAN  
JEANDELIZE  
JEUMONT  
JEUMONT-FRONTIERE  
JOEUF  
JOIGNY  
JOUE-LES-TOURS  
JUSSEY  
JUVISY  
KEHL-FRONTIERE  
KERHUON  
KUNTZIG  
LABARTHE-INARD  
LABENNE  
LABOUHEYRE  
LABRUGUIERE  
LACQ  
LACS (LES)  
LALUQUE  
LAMBALLE  
LAMOTTE-BEUVRON  
LANDEBIA  
LANDERNEAU  
LANDIVISIAU  
LANDRECIÉS  
LANGEAIS  
LANGON  
LAON  
LAROCHÉ-MIGENNES  
LAUMES-ALESIA (LES)  
LAUTERBOURG  
LAUTERBOURG-FRONTIERE  
LAVAL  
LAVANNES-CAUREL (Garage)  
LAVAU  
LAVILLEDIEU  
LEDENON  
LEFFRINCKOUCKE  
LENS

LEROUVILLE LESCAR  
LESQUIN  
LEYMENT  
LEZIGNAN-AUDE  
LEZOUX  
LIANCOURT-RANTIGNY  
LIBERCOURT LIBOURNE  
LIEUSAIN-MOISSY  
LILLE-CHAMP-DE-MARS  
LILLE-DELIVRANCE  
LILLE-FLANDRES  
LILLE-GAROLILLE  
LILLE-PORT-FLUVIAL (Garage)  
LILLERS  
LILLE-SAINT-SAUVEUR  
LILLE-SUD  
LIMOGES-BENEDICTINS  
LIMOGES-PUY-IMBERT  
LOISON  
LOISY-SUR-MARNE  
LOMME  
LONGJUMEAU  
LONGPRE-LES-CORPS-SAINTS  
LONGROY-GAMACHES  
LONGUEAU  
LONGUEIL-SAINTE-MARIE  
LONGUYON  
LORIENT LOUHANS  
LOURCHES  
LUCÉ  
LUCON  
LUMES  
LUNEL  
LUNEVILLE  
LUSIGNAN  
LYON-GUILLOTIERE  
LYON-GUILLOTIERE-PORT-  
HERRIOT  
LYON-PERRACHE  
LYON-PERRACHE-MIN  
LYON-VAISE  
MACON-PORT-FLUVIAL  
MACON-VILLE  
MADELEINE (Nord) (LA)  
MAILLY-LE-CAMP  
MAISONS-ALFORT-  
POMPADOUR MAISSE  
MALAUSE  
MALESHERBES  
MANS (LE)  
MANTES-LA-JOLIE  
MARAINVILLER  
MARAIS-DE-LOMME (Garage)  
MARCHEPRIME  
MARCHEZAIS-BROUE  
MARCK  
MARESQUEL  
MARGUT-FROMY  
MARLE-SUR-SERRE  
MARLY-LES-VALENCIENNES  
MARMANDE  
MAROEUIL  
MARSEILLE-MARITIME-ARENÇ  
MARSEILLE-PRADO  
MARSEILLE-SAINT-CHARLES

MASSY-PALAISEAU-GRANDE-  
CEINTURE MAUBEUGE  
MAZAMET  
MAZIERES-VERRUYES  
MEAUX  
MELUN MER  
MERREY (HAUTE-MARNE)  
MERU  
METZ-CHAMBRIERE  
METZ-DEVANT-LES-PONTS  
METZ-SABLON  
METZ-VILLE  
MEUNG-SUR-LOIRE  
MEUX-LA-CROIX-SAINT-OUEN  
(LE)  
MEXIMIEUX-PEROUGES  
MEZY  
MIRAMAS  
MIRIBEL  
MISSON-HABAS  
MITRY-CLAYE  
MODANE  
MODANE-FRONTIERE  
MOHON MONNAIE  
MONSEMPRON-LIBROS  
MONTAIGU-VENDEE  
MONTARGIS  
MONTATAIRE  
MONTAUBAN-DE-BRETAGNE  
MONTAUBAN-VILLE-BOURBON  
MONTBARD  
MONTBARTIER MONTCHANIN  
MONT-DE-MARSAN  
MONTEREAU  
MONTEROLIER-BUCHY  
MONTECOURT  
MONTEUX  
MONTFAVET  
MONTFORT-L'AMAURY-MERE  
MONTIERCHAUME  
MONTIERES MONTUEL  
MONTMELIAN  
MONTTOIR-DE-BRETAGNE  
MONTPELLIER  
MONTREJEAU-GOURDAN-  
POLIGNAN MORCENX  
MORHANGE MORLAIX  
MOTHE-SAINT-HERAY (La)  
MOTTEVILLE MOUESSE (Ga-  
rage)  
MOULIN-NEUF (Garage)  
MOULINS-SUR-ALLIER (Oise)  
MOURMELON-LE-PETIT  
MOUY-BURY  
MULHOUSE-DORNACH  
MULHOUSE-VILLE  
MUREAUX (LES)  
MURET  
MYENNES  
NAINTE-LES-BARRES  
NANCOIS-TRONVILLE  
NANCY-SAINT-GEORGES  
NANCY-VILLE  
NANTES-ETAT  
NANTEUIL-LE-HAUDOUIN

NARBONNE  
NEAU  
NEMOURS-SAINT-PIERRE  
NESLE (Somme)  
NEUF-BRISACH  
NEUFCHATEAU  
NEUILLY-SUR-MARNE NEUVY-  
PAILLOUX  
NEUVY-SUR-LOIRE  
NEVERS  
NICOLE  
NIMES  
NIORT  
NISSAN  
NOGENT-L'ARTAUD-CHARLY  
NOGENT-LE-PERREUX  
NOGENT-LE-ROTRON  
NOGENT-SUR-VERNISSON  
NOISY-LE-SEC  
NOTRE-DAME-D'OE  
NOTRE-DAME-DE-BRIANCON  
NOVEANT  
NOYELLES  
NOYON  
NUISEMENT  
NUITS-SAINT-GEORGES  
NUITS-SOUS-RAVIERES

---

OIRY  
OISSEL  
ORANGE  
ORGON  
ORLEANS  
ORMES-SUR-VIENNE (LES)  
ORMOY-VILLERS  
OULLINS

---

PAGNY-SUR-MEUSE  
PAGNY-SUR-MOSELLE PANTIN  
PARIS-BERCY-RAPEE  
PARIS-LA-CHAPELLE  
PARIS-TOLBIAC  
PARTHENAY PATAY  
PAU  
PAUILLAC  
PELTRE  
PENNE (LOT-ET-GARONNE)  
PERIGUEUX  
PERPIGNAN-SAINT-CHARLES  
PERRIGNY  
PERSAN-BEAUMONT  
PETIT-COURONNE  
PETIT-QUEVILLY  
PEYROUTON  
PEZOU  
PIERRELATTE  
PLANCOET  
PLANT-CHAMPIGNY (LE)  
PLEINE-FOUGERES  
PLENEE-JUGON  
PLESSIS-BELLEVILLE (LE)  
PLEYBER-CHRIST  
PLOUNERIN  
POINTE-BOUCHEMAINE (LA)  
POIRIER (LE)  
POISSY  
POITIERS

POIX-DE-PICARDIE  
POLIENAS  
POMBLIERE-SAINT-MARCEL  
POMPEY  
PONT-A-MOUSSON  
PONT-A-VENDIN  
PONT-D'ARDRES  
PONT-DE-DORE  
PONT-DE-L'ARCHE  
PONT-DE-LA-DEULE  
PONT-DE-VEYLE  
PONT-DU-CHATEAU  
PONTET (LE)  
PONTMORT  
PONT-REMY  
PONT-SAINTE-MAXENCE  
PORT-BOULET  
PORT-D'ATELIER-AMANCE  
PORT-DE-BONEUIL  
PORT-DE-PILES  
PORTES  
PORTET-SAINT-SIMON  
PORT-LA-NOUVELLE  
PORT-SAINTE-MARIE  
PORT-VENDRES-VILLE  
POUILLY-SUR-LOIRE  
POUZIN (LE)  
PROUVY-THIANT  
PUYOO

---

QUEMENEVEN QUESTEMBERT  
QUIMPER  
QUIMPERLE

---

RAISMES (Nord)  
RECQUIGNIES  
REDING REDON  
REICHSTETT (Garage)  
REIMS  
REIMS-SAINT-LEONARD (Ga-  
rage)  
REMILLY  
REMOULINS-PONT-DU-GARD  
RENNES  
RETHEL  
RETIERS  
REVIGNY  
RIBECOURT  
RICHWILLER  
RIEUX-ANGICOURT  
RIOM  
RIS-ORANGIS  
RIVES  
RIVESALTES  
ROCHEFORT  
ROCHELLE-PALLICE (LA)  
ROCHELLE-VILLE (LA)  
ROCHE-SUR-YON (LA)  
ROCHY-CONDE  
ROESCHWOOG  
ROGNAC  
ROMANS-BOURG-DE-PEAGE  
RONCHIN  
RONCQ  
ROSIERES  
ROSIERES-AUX-SALINES  
ROSNY-SOUS-BOIS

ROSNY-SUR-SEINE  
ROSPORDEN  
ROUBAIX-WATTRELOS  
ROUEN-MARTINVILLE  
ROUEN-ORLEANS  
ROUGEBARRE (Garage)  
RUE  
RUFFEC (Charente)  
RUNGIS

---

SABLE  
SAINCAIZE  
SAINT-AMAND-DE-VENDOME  
SAINT-AMAND-LES-EAUX  
SAINT-AMOUR  
SAINT-ANDRE-LE-GAZ  
SAINT-AVOLD  
SAINT-AVRE-LA-CHAMBRE  
SAINT-BRIEUC SAINT-CESAIRE  
SAINT-CHAMAS  
SAINT-CYR  
SAINT-CYR-EN-VAL  
SAINT-CYR-GRANDE-CEINTURE  
SAINT-DENIS  
SAINT-DENIS-JARGEAU  
SAINT-DIE  
SAINT-DIZIER  
SAINTE-COLOMBE-LES-VIENNE  
SAINTE-ROMAIN-EN-GAL  
SAINTE-CROIX  
SAINT-EGREVE-SAINT-ROBERT  
SAINTE-MAURE-NOYANT  
SAINT-ERME  
SAINTES  
SAINT-ETIENNE-DE-MONTLUC  
SAINT-ETIENNE-DU-ROUVRAY  
SAINT-FLORENTIN-VERGIGNY  
SAINT-FONS  
SAINT-GAUDENS  
SAINT-GERMAIN-AU-MONT-  
D'OR  
SAINT-GERMAIN-DES-FOSSES  
SAINT-GERVASY-BEZOUCHE  
SAINT-HILAIRE-AU-TEMPLE  
SAINT-HILAIRE-SAINT-NAZAIRE  
SAINT-JEAN-DE-LOSNE  
SAINT-JEAN-DE-MAURIENNE-  
ARVAN  
SAINT-JORY  
SAINT-JULIEN-CLENAY  
SAINT-JULIEN-DU-SAULT  
SAINT-JULIEN-ECUISSIS  
SAINT-JULIEN-MONTRICHER  
SAINT-JUST-EN-CHAUSSEE  
SAINT-LEGER-SUR-DHEUNE  
SAINT-LOUBES SAINT-LOUIS  
(Haut-Rhin)  
SAINT-LOUIS-LES-AYGALADES  
SAINT-MALO  
SAINT-MARCEL  
SAINT-MARTIN-DE-CRAU  
SAINT-MICHEL-SUR-CHARENTE  
SAINT-MICHEL-VALLOIRE  
SAINT-NAZAIRE  
SAINT-OMER  
SAINT-OUEN-DU-BREUIL



SAINT-OUEN-LES-DOCKS  
SAINT-PIERRE-D'ALBIGNY  
SAINT-PIERRE-DES-CORPS  
SAINT-PIERRE-DU-VAUVRAY  
SAINT-PIERRE-LA-COUR  
SAINT-PIERRE-LE-MOUTIER  
SAINT-POL-SUR-TERNOISE  
SAINT-PRIEST  
SAINT-QUENTIN  
SAINT-QUENTIN-FALLAVIER  
SAINT-RAMBERT-D'ALBON  
SAINT-ROCH (Somme)  
SAINT-SAVINIEN-SUR-CHARENTE  
SAINT-SAVIOL  
SAINT-SULPICE-AUTEUIL  
SAINT-SULPICE-LAURIERE  
SAINT-VALLIER-SUR-RHONE  
SAINT-VARENT  
SAINT-VINCENT-DE-TYROSSE  
SAINT-YRIEIX  
SALBRIS  
SALEUX  
SANTES  
SARREBOURG  
SARREGUEMINES  
SAUJON  
SAULCY  
SAULON  
SAUMUR-RIVE-DROITE  
SECLIN  
SEDAN  
SELESTAT  
SENAS  
SENNECEY-LE-GRAND  
SENS-LYON  
SERMIZELLES-VEZELAY  
SETE  
SEURRE  
SIBELIN  
SIERCK-LES-BAINS  
SILLE-GUILLAUME  
SILLERY  
SOISSONS  
SOLFERINO  
SOMAIN  
SOMMESOUS  
SORCY  
SORGUES-CHATEAUNEUF-DU-PAPE  
SOTTEVILLE  
SOUPPES SOUS-LE-BOIS  
SOUYS (LA)  
STAINS  
STRASBOURG-CRONENBOURG  
STRASBOURG-NEUDORF  
STRASBOURG-PORT-DU-RHIN  
SUCY-BONNEUIL  
SUIPPES  
SULLY-SUR-LOIRE  
SURDON  
SURGERES  
SURVILLIERS-FOSSES  
TARASCON  
TEIL (LE) (Ardèche)

TERGNIER  
TERRASSON  
THAON  
THEIL-LA-ROUGE (LE)  
THENISSEY  
THIONVILLE  
THIVIERS  
THOUARS  
THOUROTTE  
TIERCE  
TONNAY-CHARENTE  
TONNEINS  
TOUL  
TOULOUSE-MAGASINS-GENERAUX  
TOULOUSE-RAYNAL  
TOURCOING  
TOURCOING-FRONTIERE  
TOURNES  
TOURNUS  
TOURS  
TOURY  
TRACY-SANCERRE  
TRAPPES  
TREBES  
TREPORT-MERS (LE)  
TRICHERIE (LA)  
TRILPORT  
TRITH-SAINT-LEGER  
TROMPELOUP  
UCKANGE  
VAIRES-TORCY  
VALBONNE (LA)  
VALENCE-D'AGEN  
VALENCIENNES  
VALENTON-LOCAL  
VALENTON-MULTITECHNIQUE  
VALLEROY-MOINEVILLE  
VANNES  
VARANGEVILLE-SAINT-NICOLAS  
VARENNES-CHENNEVIERES (LA)  
VARENNES-SUR-ALLIER  
VAUTRY  
VAUMOISE  
VAUX-SOUS-AUBIGNY  
VAYRES  
VELAUX-COUDOUX  
VENDOME  
VENISSIEUX  
VERBERIE  
VERDON (LE)  
VERDUN  
VERGEZE-CODOGNAN  
VERNEUIL-SUR-AVRE  
VERNON (EURE)  
VERNOUILLET-VERNEUIL  
VERNOU-SUR-SEINE  
VERSAILLES-MATELOTS  
VERTAIZON  
VERTOU  
VERVINS  
VEUVE (LA)  
VICHY

VIERZON  
VIERZY  
VILLEFRANCHE-SUR-SAONE  
VILLENEUVE-D'INGRE  
VILLENEUVE-LE-ROI  
VILLENEUVE-SAINT-GEORGES-TRIAGE VILLEPARISIS  
VILLEPERDUE  
VILLERS-COTTERETS  
VILLERS-SAINT-SEPULCRE (Garage)  
VINCEY  
VITRE  
VITRY-LA-VILLE  
VITRY-LE-FRANCOIS  
VITRY-SUR-SEINE  
VOIRON  
VOREPPE  
VOULTE-SUR-RHONE (LA)  
VOUTRE  
VOVES  
WISSOUS  
WOIPPY  
WOIPPY-TRIAGE  
XERTIGNY  
YCHOUX YFFINIAC  
ZOUFFTGEN-FRONTIERE



## 9 Table 2: Loading Tables

### 9.1 Table 2<sub>1</sub>: Restrictions on load width on lines on the Continent<sup>1)</sup>

Minimum horizontal distances, in cm, to be reserved on each side between the gauge and those parts of the load situated **between the end axles or the pivots**.

Distance between the end axles or between the pivots m	Distance from the section in question to the nearest end axle or to the nearest pivot																						
	0,5	1	1,5	2	2,5	3	3,5	4	4,5	5	5,5	6	6,5	7	7,5	8	9	10	11	12	13	14	15
7,5	0	0	0	0	0	0	0	0															
8	0	0	0	0	0	1	1	1															
9	0	0	0	0	1	1	1	2	2														
10	0	0	0	1	1	2	2	2	3	3													
11	0	0	0	1	2	2	3	3	3	4	4												
12	0	0	1	2	2	3	4	4	4	5	5	5											
13	0	0	1	2	3	4	4	5	5	6	6	6	6										
14	0	0	1	2	3	4	5	6	6	7	7	7	7	7									
15	0	0	2	3	4	5	6	6	7	8	8	8	9	9	9								
16	0	1	2	3	4	5	6	7	8	9	9	10	10	10	10	10							
17	0	1	2	4	5	6	7	8	9	10	10	11	11	12	12	12	12						
18	0	1	3	4	5	7	8	9	10	11	11	12	13	13	13	14	14						
19	0	1	3	4	6	7	8	10	11	12	12	13	14	14	15	15	16	16					
19,5	0	1	3	5	6	7	9	10	11	12	13	14	14	15	16	16	16	17					
20	0	1	3	5	6	8	9	10	12	13	14	14	15	16	16	17	17	18					
20,5	0	1	3	5	7	8	9	11	12	13	14	15	16	16	17	18	19	19	19				
21	0	2	3	5	7	8	10	11	12	14	15	16	16	17	18	19	20	21	21				
21,5	0	2	4	5	7	9	10	12	13	14	15	16	17	18	19	20	22	23	23				
22	0	2	4	6	7	9	11	12	13	15	16	17	18	19	21	22	23	24	25				
24	0	2	4	6	8	10	12	14	15	17	18	20	22	24	26	27	29	31	32	32			
26	0	3	5	7	9	11	13	15	17	19	22	24	27	29	31	32	35	38	39	40	41		
28	0	3	6	8	10	13	15	17	20	23	26	28	31	33	36	38	41	44	47	48	49	50	
30	1	3	6	9	11	14	16	19	23	26	29	32	35	38	41	43	47	51	54	56	58	59	59

For dimensions, which are not given in the table, the nearest values above are to be used.

<sup>1)</sup> For lines in Finland (VR) see Table 2<sub>6</sub>

## Observations

1. The minimum horizontal distances are to be increased by 5 cm for those parts of the load situated less than 430 mm above rail level.
2. For load units liable to tip over sideways, the minimum horizontal distances must be increased by
  - 10 cm for stacks (e.g. metal trellis work) extending beyond the stanchions,
  - 5 cm for those parts of tyred vehicles without fastenings extending beyond 3200 mm (does not apply to vehicles loaded on the upper deck of double-decker wagons).
3. For loads on wagons with bogies, the minimum horizontal distances are to be increased (for those parts of the load placed between the pivots) for a distance between the axles of the bogies
  - over 4m up to 6m           by 1 cm
  - over 6 m                    by 2 cm
4. When guard wagons or an intermediate wagon are used, see also 4.3 and Table 2<sub>5</sub>.
5. In addition to be above, the following provisions shall apply in respect of (UIC) GA (Table 1<sub>2</sub>) and (UIC) GB (Table 1<sub>3</sub>) gauges: For parts of the load positioned more than 3320 mm (GA) or 3360 mm (GB) above the rails, the minimum horizontal distances shall be reduced in accordance with the table below.

<b>(UIC) GA gauge</b>							
Above height of	3 320	3 420	3 510	3 610	3 710	3 810	mm
	1	2	3	4	5	6	cm
<b>(UIC) GB gauge</b>							
Above height of	3 360	3 490	3 620	3 750	3 890	4 020	mm
	1	2	3	4	5	6	cm

**N.B.:** When this produces a negative figure, use the value: "0".

**9.2 Table 2<sub>2</sub>: (reserved)**



**9.3 Table 2<sub>3</sub>: Restrictions on load width on lines on the Continent**

Minimum horizontal distances, in cm, to be reserved on each side between the gauge and those parts of the load situated **beyond the end axles or the pivots**.

Distance between the end Axles or between the pivots m	Distance from the section in question to the nearest end axles or to the nearest pivot																					
	0.5	1	1.5	1.75	2	2.25	2.5	3	3.5	4	4.5	5	5.5	6	6.5	7	7.5	8	8.5	9	9.5	10
7.5	0	0	2	3	3	4	5	7	9	11	13	16	18	21	23	26	29	32	37	42	46	52
8	0	0	2	3	4	4	5	7	9	11	14	16	18	21	23	26	29	33	38	42	47	53
9	0	0	2	3	4	5	6	7	10	12	14	16	19	21	24	27	30	35	39	44	49	55
10	0	0	2	3	4	5	6	8	10	12	14	17	19	22	25	27	32	36	41	46	52	57
11	0	0	2	3	4	5	6	8	10	13	15	17	20	23	25	29	34	38	43	49	54	59
12	0	1	2	3	4	5	6	9	11	13	15	18	21	23	26	31	36	41	46	51	56	62
13	0	1	3	4	5	6	7	9	11	14	16	19	21	24	28	33	38	43	48	53	59	65
14	0	1	3	4	5	6	7	9	12	14	17	19	22	25	30	35	40	45	50	56	62	68
15	0	1	3	4	5	6	8	10	12	15	18	20	23	27	32	37	42	47	53	59	65	71
16	0	1	3	4	6	7	8	10	13	16	18	21	24	29	34	39	44	50	55	61	67	74
17	0	1	4	5	6	7	8	11	13	16	19	22	25	30	36	41	46	52	58	64	70	77
18	0	2	4	5	6	7	9	11	14	17	20	23	27	32	38	43	49	55	61	67	73	80
19	0	2	4	5	7	8	9	12	15	18	21	24	29	34	40	45	51	57	63	70	76	83
19.5	0	2	4	5	7	8	9	12	15	18	21	24	30	35	41	46	52	58	65	71	77	84
20	0	2	4	6	7	8	10	12	15	18	21	25	30	36	42	47	53	60	66	72	79	86
20.5	0	2	5	6	7	8	10	13	16	19	22	26	31	37	43	48	55	61	67	74	80	87
21	0	2	5	6	7	9	10	13	16	19	22	27	32	38	44	50	56	62	68	75	82	89
21.5	0	2	5	6	7	9	10	13	16	19	23	28	33	39	45	51	57	63	70	77	83	90
22	0	2	5	6	8	9	11	13	17	20	23	28	34	40	46	52	58	65	71	78	85	92
24	0	3	5	7	8	10	11	15	18	21	26	31	37	44	50	56	63	70	77	84	91	98
26	0	3	6	8	9	11	12	16	19	23	29	35	41	47	54	61	68	75	82	89	97	105
28	0	3	7	8	10	12	13	17	20	25	31	38	44	51	58	65	72	80	87	95	103	111
30	0	4	7	9	11	12	14	18	22	28	34	41	48	55	62	70	77	85	93	101	109	118

For dimensions, which are not given in the table, the nearest values above are to be used.

**Observations**

- The minimum horizontal distances are to be increased by 5 cm for those parts of the load situated less than 430 mm above rail level.
- For load units liable to tip over sideways, the minimum horizontal distances must be increased by:
  - 10 cm for stacks (e.g. metal trellis work) extending beyond the stanchion,
  - 5 cm for tyred vehicles without fastenings on the parts extending beyond 3200 mm (does not apply to vehicles loaded on the upper deck of double-decker wagons).
- When guard wagons or an intermediate wagon are used, see also paragraph 4.3 and Table 2<sub>5</sub>.
- In addition to the above, the following provisions shall apply in respect of (UIC) GA (Table 1<sub>2</sub>) and (UIC) GB (Table 1<sub>3</sub>) gauges:  
For parts of the load positioned more than de 3320 mm (GA) or 3360 mm (GB) above the rails, the minimum horizontal distances shall be reduced in accordance with the table below:

<b>(UIC) GA gauge</b>						
Above height of	3 320	3 420	3 510	3 610	3 710	3 810 mm
	1	2	3	4	5	6 cm
<b>(UIC) GB gauge</b>						
Above height of	3 360	3 490	3 620	3 750	3 890	4 020 mm
	1	2	3	4	5	6 cm

**N.B.:** When this produces a negative figure, use the value: "0".





**9.4 Table 2<sub>4</sub>: (reserved)**



**9.5 Table 2<sub>5</sub> Restrictions on load width on lines on the Continent**

Minimum horizontal distances, **in cm**, to be reserved on each side, between the loads and the side walls or stanchions of guard wagons or intermediate wagons.

Distance between the end axles or the pivots of the carrying wagon	Distance, in cm, from the load to the side walls or stanchions <sup>1)</sup>									
	guard wagons for a distance, from the section in question to the end axle of the carrying wagon or to the nearest pivot									From the in-termediate wagon
m	3	4	5	6	6,5	7	8	9	10	
<b>4</b>	26									
<b>6</b>	26	31	38	45	49	53	61	70	80	
<b>8</b>	26	32	39	47	50	55	63	72	83	
<b>10</b>	28	34	41	49	54	58	67	77	88	<b>24</b>
<b>12</b>	29	36	44	52	57	61	71	81	93	<b>28</b>
<b>14</b>	31	38	47	56	60	65	76	86	98	<b>33</b>
<b>16</b>	33	41	50	59	64	69	80	92	104	<b>38</b>
<b>18</b>	34	43	53	63	68	73	85	97	110	<b>44</b>
<b>20</b>	36	46	56	67	72	78	90	102	116	<b>51</b>
<b>25</b>	41	52	64	76	83	89	103	117	132	<b>71</b>
<b>30</b>	46	58	72	86	93	100	116	131	148	<b>95</b>

For those dimensions, which are not given in the table, the nearest values above are to be used.

<sup>1)</sup> Loads for which the minimum horizontal distances are given in bold type are to be considered special consignments (number 7)



### 9.6 Table 2<sub>6</sub>: Restrictions on load width on lines in Finland (VR)

Minimum horizontal distances, in cm, to be reserved on each side between the gauge and those parts of the load situated **beyond the end axles or the pivots**.

Distance between the end axles or between the pivots	Distance from the section in question to the nearest end axle or to the nearest pivot											
m	5,0	5,5	6,0	6,5	7,0	7,5	8,0	8,5	8,75	9,0	9,5	10,0
17,0	0	0	0	0	0	0	0	0				
17,5	0	0	0	0	0	0	0	0	0			
18,0	0	0	0	0	0	0	1	1	1	1		
19,0	0	0	0	1	2	3	4	4	4	4	4	
20,0	0	1	2	3	5	5	6	7	7	7	7	8

For dimensions, which are not given in the table, the nearest values above are to be used.

#### Observations

1. The minimum horizontal distances are to be increased by 7.5 cm for those parts of the load situated less than 330 mm above rail level.
2. For load units liable to tip over sideways, the minimum horizontal distances must be increased by
  - 10 cm for stacks (e.g. metal trellis work) extending beyond the stanchions,
  - 5 cm for those parts of tyred vehicles without fastenings extending beyond 3200 mm (does not apply to vehicles loaded on the upper deck of double-decker wagons)



**9.7 Table 27: Restrictions on load width on lines in Finland (VR)**

Minimum horizontal distances, in cm, to be reserved on each side between the gauge and those parts of the load situated **beyond the end axles or the pivots**.

Distance between the end axles or between the pivots m	Distance from the section in question to the nearest end axle or to the nearest pivot											
	1,2	1,5	2,0	2,5	3,0	3,5	4,0	4,5	5,0	5,5	6,0	6,5
6,0	0	1	2	2	3							
7,0	0	0	1	2	3	3						
8,0	0	0	1	1	2	3	3					
9,0	0	0	0	1	2	2	3	3				
10,0	0	0	0	1	1	2	2	3	4			
11,0	0	0	0	0	1	1	2	2	5	9		
12,0	0	0	0	0	1	1	2	2	7	11	15	
13,0	0	0	0	0	0	1	1	4	7	12	17	21
14,0	0	0	0	0	0	1	1	5	9	14	18	23
15,0	0	0	0	0	0	0	2	6	11	15	20	25
16,0	0	0	0	0	0	0	3	7	12	17	22	27
17,0	0	0	0	0	0	0	4	9	14	18	23	29
18,0	0	0	0	0	0	1	6	10	15	20	25	31
19,0	0	0	0	0	0	2	7	11	17	22	27	33
20,0	0	0	0	0	0	3	8	13	18	23	30	35

For dimensions, which are not given in the table, the nearest values above are to be used.

**Observations**

1. The minimum horizontal distances are to be increased by 7.5 cm for those parts of the load situated less than 330 mm above rail level.
2. For load units liable to tip over sideways, the minimum horizontal distances must be increased by
  - 10 cm for stacks (e.g. metal trellis work) extending beyond the stanchions,
  - 5 cm for those parts of tyred vehicles without fastenings extending beyond 3200 mm (does not apply to vehicles loaded on the upper deck of double-decker wagons)





**10 Table 3: Flaps on flat wagons which can be lowered without infringing the international gauge**

UIC code No	Railway Undertaking	Wagons				Number of flaps per side	
		Letter code	Serial n°s		Total	which must be lowered	
51	PKP	Kbkk	300 0 000	- 301 3	999	6	all
		K/Kbkk	321 0 000	- 321 7	999	6	all
		K/Kbkk	322 1 000	- 322 2	999	6	4 centre
		Ks	330 0 000	- 330 9	999	6	4 centre
		Ks/Kbkks	341 5 000	- 341 7	999	5	4 centre
52	BDZ	Ras	393 ..			8	all
54	CD	Kbkks	341 5 ...	- 341 6	...	7	all
		Res	394 1 ...	- 394 4	...	9	all
55	MAV	Ks	330 0 000	- 330 7	999	6	all
		Lg	441 6	...		6	all
56	ZSSK	Kbkks	341 5 ...	- 341 6	...	7	all
		Res	394 1 ...	- 394 4	...	9	all
64	FNME	Kkklm	328 3 000	- 328 3	010	4	all
65	MZ	Kbs	333 0 200	- 333 0	245	6	4 centre
71	RENFE	Ks	330 1 000	- 330 1	049	6	all
		Ks	330 0 000	- 330 0	412	6	all
72	JZ	Kbs	333 0 200	- 333 0	249	6	4 centre
73	CH	-	-			-	-
79	SZ	Kgs	332 9 000	- 332 9	079	7	all
		Regs-z	392 4 002	- 392 4	112	8	all
80	DB	Ks 446	330 0 000	- 330 1	191	6	4 centre
		Ks 447	330 1 500	- 330 1	799	6	4 centre
		Kbs 443	333 0 000	- 333 6	785	6	4 centre
		Kbs 442	333 7 000	- 334 8	599	6	4 centre
		Kbs 442	335 0 650	- 335 0	999	6	4 centre
		Kls 443	336 0 000	- 336 3	399	6	4 centre
		Kls 442	336 5 000	- 336 9	999	6	4 centre
		Klps 444	339 0 000	- 339 0	129	4 <sup>1)</sup>	4 centre
		Kls-x 448	346 7 000	- 346 8	361	6	4 centre
		Res 675	394 2 000	- 394 2	499	8	6 outer
		Res 677	394 2 500	- 394 2	749	9	6 outer
		Res 676	394 2 750	- 394 2	751	9	all
		Res 677	394 2 752	- 394 2	886	9	6 outer
		Res 676	394 2 887	- 394 2	999	9	all
		Res 676	394 3 000	- 394 3	999	9	all
		Res 676	394 4 000	- 394 4	134	9	all
Res 678	399 7 000	- 399 7	543	9	all		
Samms-u 454	486 0 000	- 486 0	999	6	all		
Samms-u 454	486 6 000	- 486 6	599	6	all		
Samms-u 453	486 7 000	- 486 7	765	7	all		

<sup>1)</sup> outer flaps missing

UIC code No	Railway Undertaking	Wagons			Number of flaps per side	
		Letter code	Serial n°s			
81	OBB	Ks	330 0 ...		6	4 centre
		Ks	331 0 ...		6	4 centre
		Ks	331 0 ...		6	4 centre
		Kbs	333 0 ...		6	4 centre
		Kbs	334 0 ...		6	4 centre
		Kbs	334 1 ...		6	4 centre
82	CFL	Ks	330 0 101 - 330 0 250		6	4 centre
		Ks	330 1 101 - 330 1 200		6	4 centre
		Kkks	340 4 001 - 340 4 067		6	4 centre
		Res	393 6 101 - 393 6 210		9	4 outer
		Renns	399 0 001 - 399 0 080		9	4 outer
83	FS	Ks	330 0 000 - 330 1 499		6	4 centre
		Ks	332 0 000 - 332 0 199		6	4 centre
		Km	310 0 000 - 310 0 398		6	4 centre
		Kkkm	320 5 000 - 320 5 391		6	4 centre
		Kms/Kkms	340 0 000 - 340 0 098		6	4 centre
85	SBB/CFF	Ks	330 0 ... - 330 1 ...		6	4 centre
86	DSB	Ks	330 0 000 - 330 0 299		6	4 centre
		Kbs	333 0 000 - 333 0 449		6	4 centre
87	SNCF	Ks	330 6 700 - 330 9 199		6	4 centre
		Ks	331 0 400 - 331 1 399		6	4 centre
		Ks	331 2 000 - 332 0 499		6	4 centre
		Ks	332 1 875 - 332 2 999		6	4 centre
		Ks	332 3 550 - 332 4 099		6	4 centre
		Ks	332 4 100 - 332 4 249		6	4 centre
		Ks	332 8 850 - 332 8 999		6	4 centre <sup>1)</sup>
		Res	393 8 500 - 394 2 799		9	2 outer
		Res	394 7 950 - 394 7 999		9	2 outer
		Lfls	414 5 200 - 414 5 299		6	all
88	SNCB	Ks	330 4 000 - 330 5 149		6	all
		Ks	330 0 000 - 330 0 899		5	all

<sup>1)</sup> The two centre flaps only for wagons forwarded to Spain or to Portugal

## 11 Table 4: Impact test for loading methods and loose fastenings

### 11.1 Purpose

The purpose of these tests is to check whether the loading methods used, and loose fastenings stand up to the longitudinal stresses exerted during railway operating.

### 11.2 Test conditions

#### 11.2.1 Impact wagon

The wagon shall be:

- a high-sided open bogie wagon,
- fitted with category A sided buffers in accordance with **UIC leaflet 526-1**,
- loaded to a total mass of 80 t, preferably with bulk goods,
- kept stationary on flat straight track in the unbraked position by means of stop blocks positioned at a distance of approximately one meter.

#### 11.2.2 Wagon loaded according to the method requiring testing

The wagon must be:

- loaded as far as possible to maximum capacity (part load: insufficient), in order to limit investment in means of fastening,
- fitted in principle with categories A and B side buffers, in accordance with **UIC leaflets 526-1** or **526-2**.

The results of tests carried out with wagons with buffers in accordance with **UIC leaflet 526-1**, category C, or **UIC leaflet 526-3** may not be transposed to wagons fitted with conventional buffers (**UIC leaflet 526-1**, categories A and B, and **UIC leaflet 526-2**).

The floor of the wagon shall be

- clean,
- free from any load debris, fastenings, snow or ice.

The state of the floor (e.g. wet or dry) must be stated in the report.

#### 11.2.3 Position of the impact wagon

For testing purposes, the impact wagon may also impact the wagon loaded according to the method which is being tested.

#### 11.2.4 Impact programme

The speeds given in the tolerance ranges hereafter are reference speeds, the results recorded are to be interpreted in line with paragraph 11.3.

##### 11.2.4.1 Full wagons fly or gravity shunted

2 impacts in the same direction,

- 1st impact at 5-7 km/h
- 2nd impact at 8-9 km/h

followed, without any adjustment of the load fastenings, by

- counter-shock at 8-9 km/h.

The need to carry out a counter-shock must be assessed on the basis of the results of the two previous impacts with account taken, where appropriate, of the features of the goods carried and loading type.

##### 11.2.4.2 Full wagons not fly or gravity shunted (block trains)

Two impacts in the same direction, both at 3-4 km/h.

### 11.2.5 Measurement of impact speeds

- Measurement track section preferably to be marked with primer caps,
  - End of the section situated approximately 10 m from the buffers on the impact wagon,
  - Measurement by means of a chronometer and conversion using the "time/impact speed concordance table given under paragraph 11.5 of the tolerance ranges given under paragraph 11.2.4.1.
- Stopping testing:  
skids placed between the measurement track section and the impact wagon to act as an emergency brake which can stop testing if required.  
**Scenario 1:** if the impact speed as per paragraph 11.3 hereafter is not considered useable, the skids are to be left in place.  
**Scenario 2:** if the impact speed is considered correct, then the skids are to be removed immediately (e.g. using a wire).
  - It is also possible to apply more sophisticated measurement techniques.

### 11.3 Analysis of results

After the impact programme has been carried out in accordance with paragraph 11.2.4

- operating safety must be preserved
- the fastenings, wagon gear and load must be free of damage.

In the case of loads likely to move about freely in the lengthwise direction across the wagon, the analysis will focus on the distance covered by the load during the second impact.

The result of the test must be recorded in accordance with template 1.

### 11.4 Dangerous goods (RID)

For the purposes of impact tests, RID goods are assimilated to other transported goods. Other conditions which apply are set out in the version of the RID in force.

### 11.5 Conversion table

km/h	Impact speed					
	Measurement section					
	5 m	6 m	7 m	8 m	9 m	10 m
	Second"					
3	6.00	7.20	8.40	9.60	10.80	12.00
4	4.50	5.40	6.30	7.20	8.10	9.00
5	3.60	4.32	5.04	5.76	6.48	7.20
7	2.57	3.09	3.60	4.11	4.63	5.14
8	2.25	2.70	3.15	3.60	4.05	4.50
9	2.00	2.40	2.80	3.20	3.60	4.00

**12 Table 5: Goods transported under special aerodynamic conditions in long tunnels**

<b>ISO-3166-2 country code</b>	<b>Tunnel</b>	<b>from-to (both directions)</b>	<b>Goods forming the load</b>
CH	Gotthard Base	Rynächt – Pollegio North	Bulk goods with grain size < 16/32 (except ore pellets)



# | 13 Template 1

Issuing Railway Undertaking

Loading method:  $\frac{000^{2)}}{0000^{3)}-000^{4)}-00^{5)}$

		Title (type of goods)
Single wagons and groups of wagons	Wagons in block trains or combined transport	
	Wagons with long-stroke shock absorbers	

## Type of goods

## Wagon

## Method of loading

## Securing

- lengthways

- crossways

## Additional indications

For loading examples (pink sheets), indicate derogations from UIC Loading Guidelines, volume 1:



**Behaviour of load during buffing impacts as per table 4**

- strongest impact:.....km/h
- (condition of the load, the securing elements and where appropriate the wagon components following the next impact)
- (where appropriate: the extent of displacement of the goods)
- (where appropriate: why were no buffing tests carried out or why did the tests not comply with table 4)

**Information on a loading example**

Loading example, approved by .....

**Issuing Railway Undertaking:**

Sheet	$\frac{000^{2)}}{0000^{3}-000^{4}-00^{5}}$	sheet	This sheet replaces $\frac{000^{2)}}{0000^{3}-000^{4}-00^{5}}$
-------	--	-------	---

- 1) Paper colour:
  - blue, information on a loading method compliant with volume 1,
  - pink, information on a loading method not fully compliant with volume 1 which is the subject of an agreement between RUs,
  - yellow, information on a loading method for domestic traffic which is not fully compliant with volume 1.
- 2) Chapter number as per table of contents of volume 2 (e.g.: 001=Metal, 002=Wood, etc.)
- 3) RICS Code number of issuing RU
- 4) Registration in edition year
  - serial number for blue sheets (starting with 001),
  - serial number for pink sheets (starting with 101),
  - letter selected in alphabetical order for yellow sheets.
- 5) Edition year



### **Warning**

No part of this publication may be copied, reproduced or distributed by any means whatsoever, including electronic, except for private and individual use, without the express permission of the International Union of Railways (UIC). The same applies for translation, adaptation or transformation, arrangement or reproduction by any method or procedure whatsoever. The sole exceptions - noting the author's name and the source -are "analyses and brief quotations justified by the critical, argumentative, educational, scientific or informative nature of the publication into which they are incorporated" (Articles L 122-4 and L122-5 of the French Intellectual Property Code).

© International Union of Railways (UIC) - Paris, 2020

Printed by the International Union of Railways (UIC)  
16 rue Jean Rey, 75015 Paris – France  
Legal deposit January 2020

ISBN 978-2-7461-2894-1 (French version)  
ISBN 978-2-7461-2888-0 (German version)  
**ISBN 978-2-7461-2889-7 (English version)**